

GLORY Currency Reader Counter

# GFR-S80

**Service Manual**

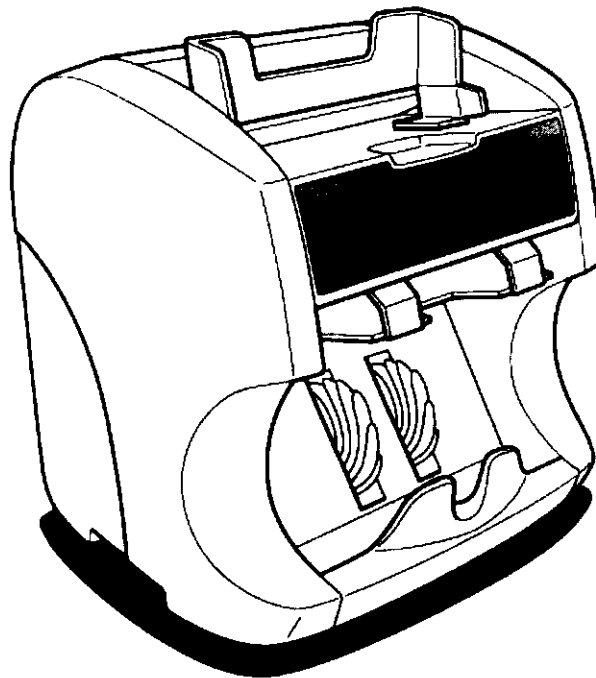

# Contents

1.	<b>A p p e a r a n c e a n d n a m e s o f m a i n p a r t s</b>	
	【 1 】 Appearance .....	1
	【 2 】 Display panel .....	2
	【 3 】 Operating key functions .....	2
2.	<b>G F R - S 8 0 S p e c i f i c a t i o n s</b>	
	【 1 】 Dimension .....	5
	【 2 】 Weight .....	5
	【 3 】 Counting rate .....	5
	【 4 】 Currency to be processed .....	5
	【 5 】 Feeding method .....	5
	【 6 】 Hopper capacity .....	5
	【 7 】 Stacker capacity .....	5
	【 8 】 Reject stacker capacity .....	5
	【 9 】 Power supply .....	5
	【 1 0 】 Power consumption .....	5
	【 1 1 】 Requirements of operating environment .....	5
	【 1 2 】 Option .....	6
	【 1 3 】 Durability .....	6
	【 1 4 】 Instruction for installation .....	6
3.	<b>M a i n f u n c t i o n s</b>	
	【 1 】 M I X mode (Deposit with denomination discrimination) .....	7
	【 2 】 D.D. mode (Different denomination separation) .....	8
	【 3 】 C N T mode (Count) .....	10
4.	<b>T h e l i s t o f u s e r R A S s e t t i n g</b>	
	【 1 】 Outline .....	11
	【 2 】 Method to start .....	11
	【 3 】 Select of set items .....	11
	【 4 】 Method to stop .....	11
	【 5 】 Details of each item .....	12

5.	I n s t r u c t i o n s   f o r   m a i n t e n a n c e	
	[ 1 ] Cleaning sensors .....	21
	[ 2 ] Cleaning rollers and belts .....	22
	[ 3 ] Adjusting gate gap with thickness adjusting screw .....	22
	[ 4 ] Instruction to remove covers from machine .....	22
	[ 5 ] Instruction to rewrite ROM .....	24
	[ 6 ] Instruction to exchange power supply .....	25
	[ 7 ] Instruction to exchange magnetic heads .....	25
	[ 8 ] Instruction to exchange reflection sensor .....	26
	[ 9 ] Instruction to exchange feed rollers .....	27
	[ 1 0 ] Instruction to exchange kicker rollers .....	29
	[ 1 1 ] Instruction to exchange pulling rollers .....	29
	[ 1 2 ] Instruction to exchange brush rollers .....	30
	[ 1 3 ] Instruction to exchange main motor .....	30
	[ 1 4 ] Instruction to exchange solenoids .....	31
6.	A d u s t m e n t   o f   e a c h   p a r t	
	[ 1 ] Adjusting gate .....	32
	[ 2 ] Phase adjustment of kicker rollers and feed rollers. ....	33
	[ 3 ] Adjusting brake. ....	34
	[ 4 ] Adjusting clutch. ....	34
	[ 5 ] Adjusting timing belt. ....	34
	[ 6 ] Aligning nails for currency separation. ....	35
	[ 7 ] Aligning roller catch. ....	35
	[ 8 ] Set up of power supply, sensor adjustment, mini-jumpers and switches .....	35
	[ 9 ] Sensor layout. ....	36
7.	C o n n e c t i n g   o p t i o n a l   p a r t s	
	[ 1 ] Components to be Mounted .....	37
	[ 2 ] Set up of mini jump and D I P S W .....	37
	[ 3 ] Installation procedure .....	38

8.	R A S s p e c i f i c a t i o n	
[ 1 ]	Layout of displays and operation keys .....	39
[ 2 ]	Starting and finishing R A S mode .....	39
[ 3 ]	Operation key functions .....	40
[ 4 ]	Input operation for RAS menu .....	41
[ 5 ]	List of RAS items .....	42
[ 6 ]	RAS Operating Specifications .....	44
9.	T r o u b l e s h o o t i n g	
[ 1 ]	Display of error code .....	71
[ 2 ]	Clearing an error .....	71
[ 3 ]	List of error codes .....	72
[ 4 ]	Error detecting condition .....	73
10.	G e n e r a l w i r i n g d i a g r a m .....	85

1. Appearance and name of main parts

[ 1 ] Appearance

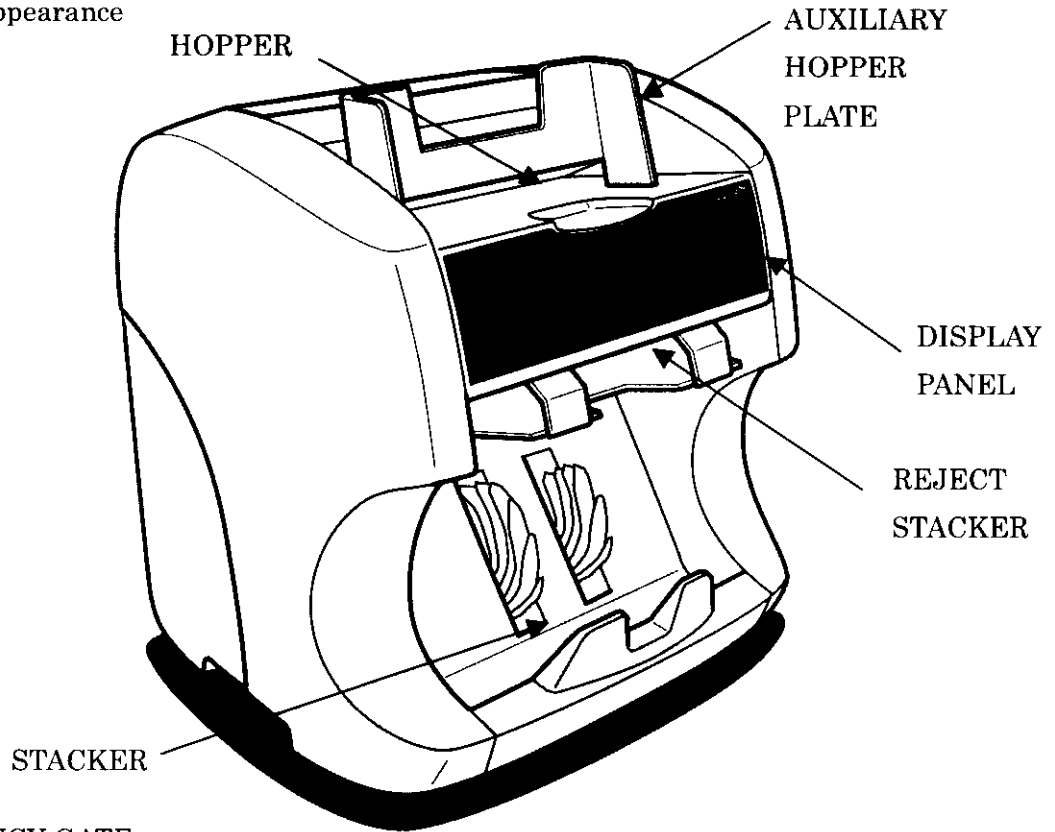

CURRENCY GATE  
ADJUSTMENT  
SCREW

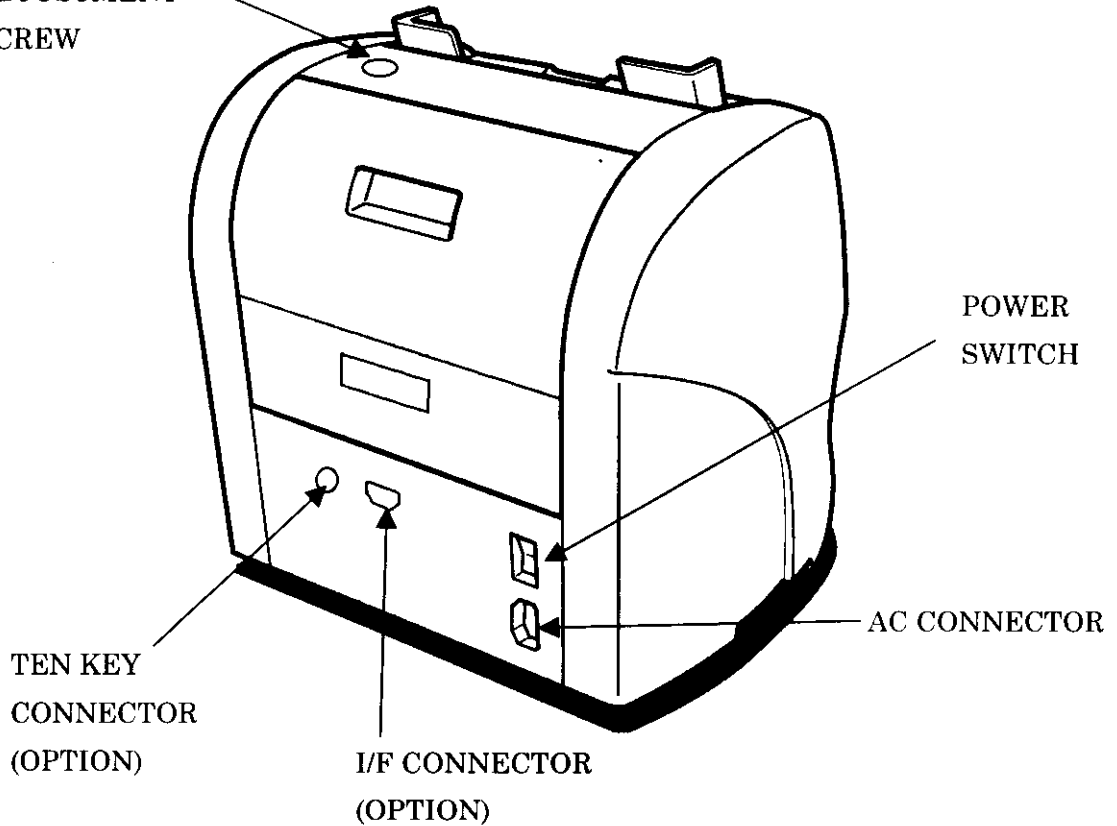

**【 2 】 Display panel**

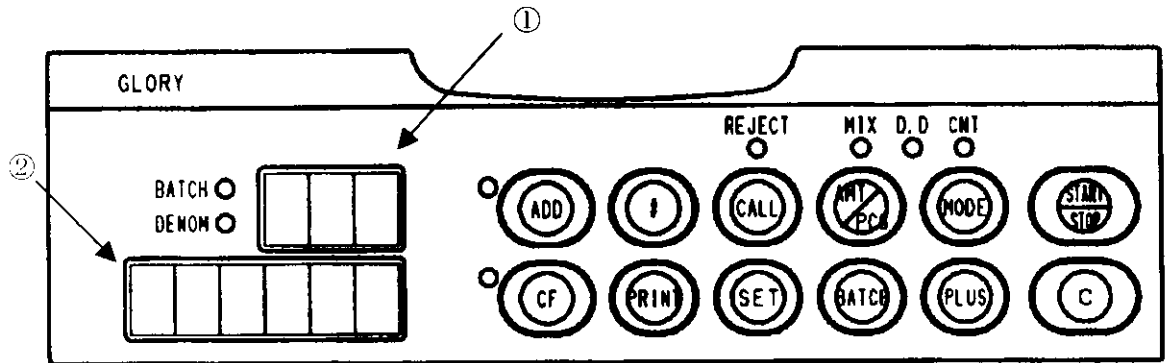

- ① Batch.....MIX—Blank, D. D•CNT—Batch number
- ② Pieces•Amount.....MIX•D. D—Pcs. Amt., CNT—Pcs.

**【 3 】 Operating key functions**



..... Counting start/stop  
 • Starts and stops counting.

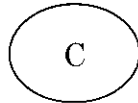

..... Clear  
 • Clears errors.  
 • Clears all kinds of denomination information.  
 (Counted piece and amount of grand total and each denomination.)



..... Switches modes

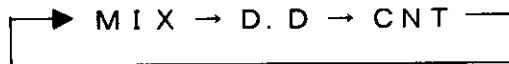

※ As modes are changed, data counted are cleared to 0.



..... Plus

- In D.D. and CNT mode, the number of batch (Arbitrary pieces counting) is changed in increments of 1.
- Incremental speed is increased by holding the key more than 1 sec.
- Max. 200 pcs. ( 2 0 0 → 1 → 2 → ..... )



..... Switches between pieces and amount display.

- In Mix and D.D. mode, the number displayed is switched between. Pieces and amount of a denomination.
- The number displayed during CALL key operation can be switched like above, too.



..... Batch

- In D.D. and CNT mode, the number of batch (Arbitrary pieces counting) is changed in increments of preset values shown below.

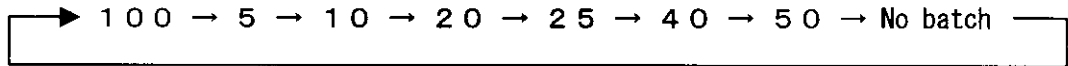

- Using this function, counting data are cleared to 0.
- ※5,10,20,25,40,50,100 are default values.



..... Call

- In Mix mode, counted piece or amount of a specific denomination is displayed.
- A total pcs./amt. of all denominations is displayed, too. Single pressing of the key changes the displaying values as shown below.

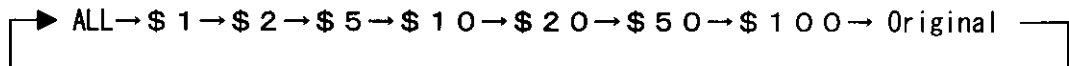

- Choosing a specific denomination, and its total pcs./amt. values is displayed.
- Pressing key permits escape from the CALL loop at any time.



..... Changes user RAS parameters

- Evoke and enable to change user RAS parameters.
- Each parameter of user RAS is available to change.

#

.....Total data is printed out.

※ In RAS mode(Power up while pressing **ADD** + **C** keys.)

- Data logs
- Single step movement executions
- Sensor adjustments

PRINT

..... Data hardcopy

- Prints out data
- Ignored when no data exist

ADD

..... Add function ON / OFF

- Continues to add counted Amt/Pcs value with a previously counted value.

CF

..... Counterfeit detection ON / OFF switch

- Counterfeit detection level ON / OFF.

## 2. GFR-S 80 Specifications

### 【1】 Dimension

Without auxiliary hopper plate : 310 (W) × 275 (D) × 295 (H) mm

With auxiliary hopper plate : 310 (W) × 330 (D) × 295 (H) mm

### 【2】 Weight

Approx. 12kg

### 【3】 Counting rate

1000 pcs./min.

### 【4】 Currency to be processed

M I X · D . D : US\$ currencies ( \$ 1,2,5,10, 20,New 20,

50,New 50,100,New 100)

C N T : 62×100~75×160mm sheets

### 【5】 Feeding method

Roller friction

### 【6】 Hopper capacity

About 300 pcs.

### 【7】 Stacker capacity

About 200 pcs.

### 【8】 Reject stacker capacity

About 20 pcs.

### 【9】 Power supply

Rated voltage : 120V ± 10%

Frequency : 60H z

### 【10】 Power consumption

In operation : 1.2A

Idle : 0.4A

### 【11】 Requirements of operating environment

Temperature : 0°C~35°C

Humidity : 20%~90% R H

**【 1 2 】 Option**

Ten key for manual input : Manual input by compatible with PS/2 ten keypad.

Available only when a printer is connected.

Printer interface (RS232C) : Citizen IDP3540 F40RF120-IB  
Or its compatible

PC interface (RS232C) : I/F to PC terminal via RS232C

**【 1 3 】 Durability**

15 million pcs. = 10,000 pcs./day × 300 days/year × 5years

**【 1 4 】 Instruction for installation**

To install properly, keep the space as shown below.

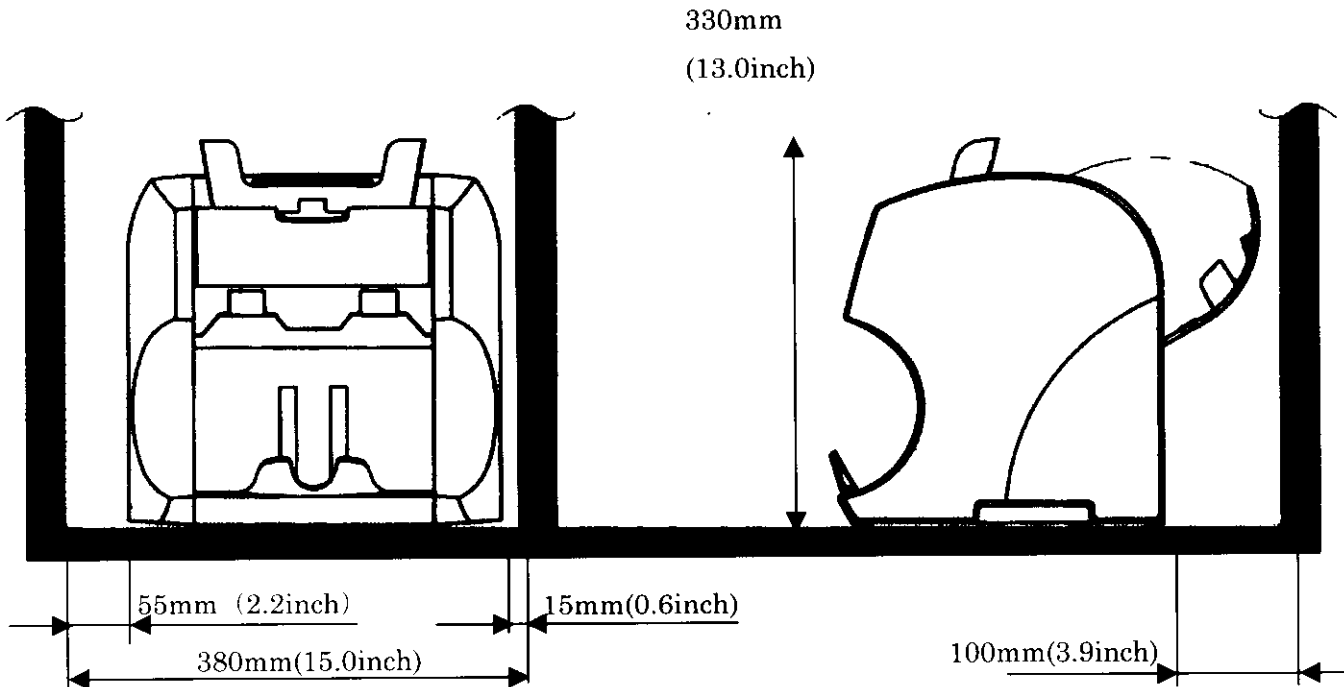



**【 2 】 D.D. mode (Different denomination separation)**

- ① Put banknotes mixed on the hopper.
- ② Display amount or number of the notes of the denomination counted first. (That denomination becomes the standard.)
- ③ The banknotes of the denomination counted first are counted; otherwise, rejected.

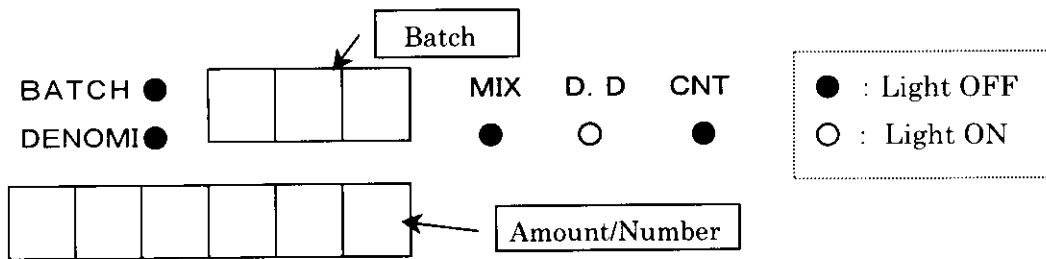

※ When counting with a batch function.

When counted amount/number are less than that is set as batch, Amount/number display blinks.

※ **CALL** Counted amount or pieces of each denomination is displayed by pressing this key.

Total amount or pieces of all denominations is displayed at ALL.

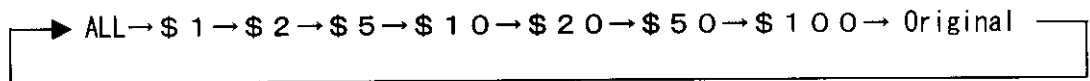

**START/STOP** Pressing the key makes the display return to the original whatever is displayed at that time.

~~ Reject Stacker ~~

Skew, Interval, Double, Counterfeit, Undiscriminated

※ How to set batch

Method 1

1) Go to D.D. mode.

2) **CALL** By pressing the key, select the denomination to set batch for it.

▶ ALL → \$ 1 → \$ 2 → \$ 5 → \$ 1 0 → \$ 2 0 → \$ 5 0 → \$ 1 0 0 → Original

3) By pressing the key, set batch to any number. (Numbers below are default.)

▶ 1 0 0 → 5 → 1 0 → 2 0 → 2 5 → 4 0 → 5 0 → No batch

OR **PLUS** By pressing the key, set batch to any number. (Max. 200 pcs.)

4) **START  
STOP** By pressing the key, enable the panel to display batch.

Method 2

1) Go to D.D. mode.

2) **CALL** Press the key.

3) **BATCH** By pressing the key, set batch. (Numbers below are default.)

▶ 1 0 0 → 5 → 1 0 → 2 0 → 2 5 → 4 0 → 5 0 → No batch

OR **PLUS** By pressing the key, set batch to any number. (Max. 200 pcs.)

4) **CALL** By pressing the key, select the denomination to set batch.

▶ ALL → \$ 1 → \$ 2 → \$ 5 → \$ 1 0 → \$ 2 0 → \$ 5 0 → \$ 1 0 0 → Original

5) **START  
STOP** By pressing the key, enable the panel to display batch.

Notice: If the batch number for "ALL" is set and it is different from the batch number for each denomination, the displayed number for "ALL" batch blinks.

**【3】 CNT mode (Count)**

- ① Put notes on the hopper.
- ② The machine counts them.
- ③ Display total number of notes is displayed.

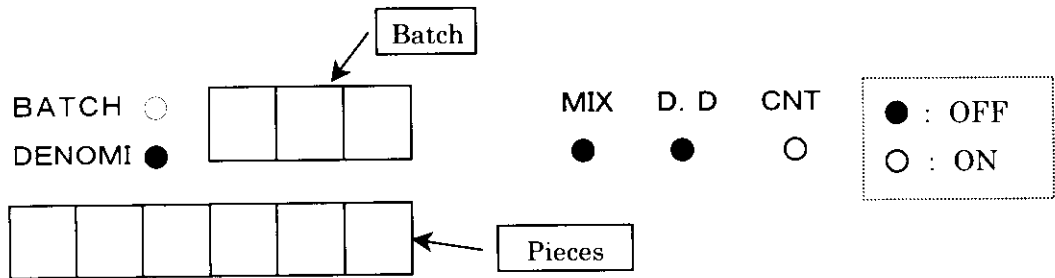

※In CNT mode, denominations are not discriminated or note values are not recognized.

Any notes besides US currency might be counted.

(Countable size: 62×100~75×160mm (Single size of notes is preferred.))

~~ Reject Stacker ~~

Skew, Interval, Double

※ How to set batch

1) Go to CNT mode.

2) **BATCH** By pressing the key, set batch. (Numbers below are default.)

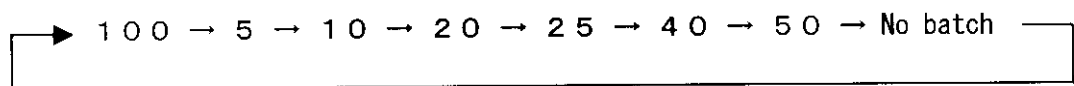



OR **PLUS** By pressing the key, set arbitrary batch to any number. (Max. 200 pcs.)

#### 4. The list of user RAS setting

##### 【 1 】 Outline



By user RAS setting, a variety of functions are set by a user.

##### 【 2 】 Method to start

During idle (no error) while Pressing the keys  pressing the key .

##### 【 3 】 Select of set items

 Every pressing of the key switch sets items in order shown below.

 No. 1 → No. 2 → No. 3 → . . . No. B → idle 

※ Cursor (Blinking) for each item, when actuated, is located at the previously set one.

##### 【 4 】 Method to stop

###### Method 1

During each item, pressing the key .

###### Method 2

Pressing the key  several times, then return to idle makes the mode.

【 5 】 Details of each item

① Terminal interface ON/OFF

1) Function

Sets terminal interface to used or not. (2 levels)

Default value: OFF

※ When a printer interface is set to ON, terminal interface is disabled (OFF) .

2) Display

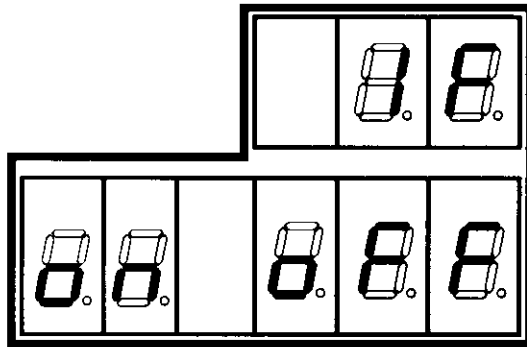

※Selected value blinks

3) Key

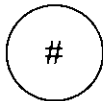

Key . . . A cursor moves in order of ▶ON → OFF◀



Key . . . Value selected by a cursor becomes new value, then go to No.2 item setup.



Key . . . Value selected by a cursor becomes new value, then go to idle.

② Autostart ON/OFF

1) Function

Selects autostart ON or OFF (2 levels)

Default value: ON

2) Display

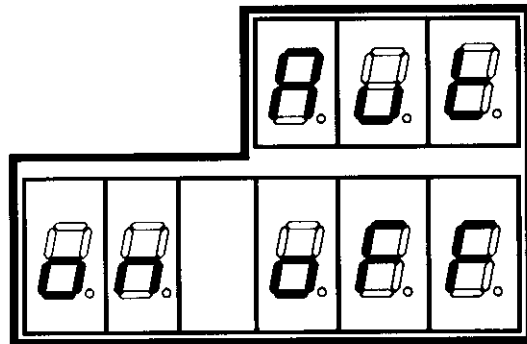

※Selected value blinks

3) Key

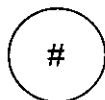

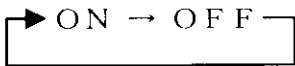
Key . . . A cursor moves in order of 



Key . . . Value selected by a cursor becomes new value, then go to No.3 item setup.



Key . . . Value selected by a cursor becomes new value, then go to idle.

③ Repeat-start ON/OFF

1) Function

Select repeat-start ON or OFF (2 levels)

Default value: ON

2) Display

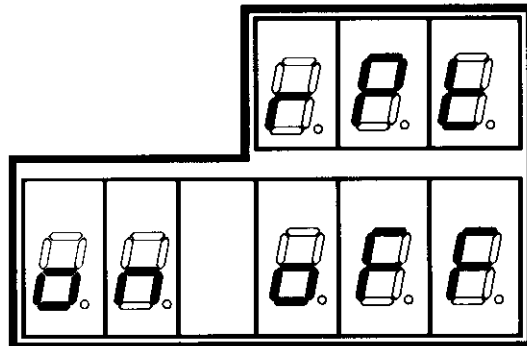

※Selected value blinks

3) Key

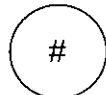

Key . . . A cursor moves in order of ▶ ON → OFF ◀



Key . . . Value selected by a cursor becomes new value, then go to No.4 item setup.



Key . . . Value selected by a cursor becomes new value, then go to idle.

④ Counterfeit detection STOP/CONTINUE

1) Function

In Mix mode and D.D. mode, enables counterfeit detection or not.

(2 levels)

When a counterfeit bill is detected, it is transferred to the reject stacker.

Default value: Ct

2) Display

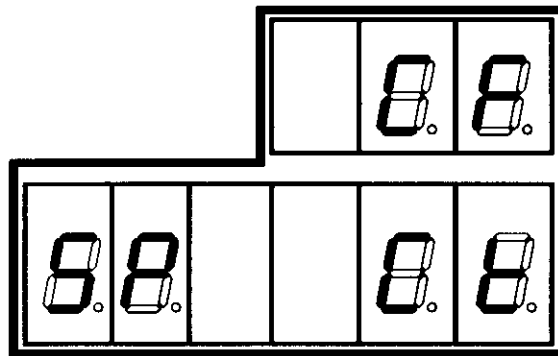

※Selected value blinks

3) Key

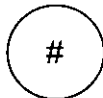

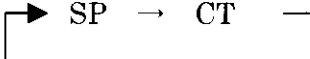
Key . . . A cursor moves in order of  SP → CT



Key . . . Value selected by a cursor becomes new value, then go to No.5 item setup.



Key . . . Value selected by a cursor becomes new value, then go to idle.

⑤ Face sorting ON/OFF

1) Function

[In Mix and D.D. modes,] enables "face sorting" or not. When enabled, only currencies with their faces up as determined by the first currency are sent to the stacker. All the others are sent to the reject stacker.

Default value: OFF

2) Display

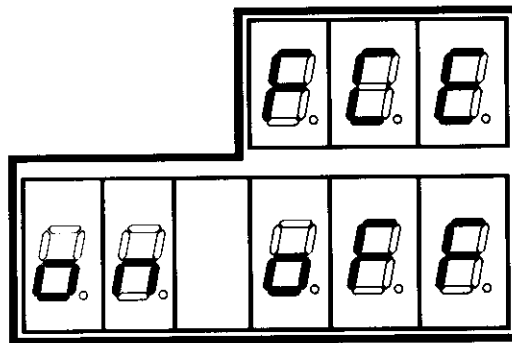

3) Key

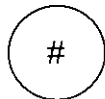

Key . . . A cursor moves in order of ▶ ON → OFF ◀



Key . . . Value selected by a cursor becomes new value, then go to No.6 item setup.



Key . . . Value selected by a cursor becomes new value, then go to idle.

⑥ Double sheet detection level (For count mode)

1) Function

Select the double sheet detection level for Count mode. (5 levels)

Default value: Level 3

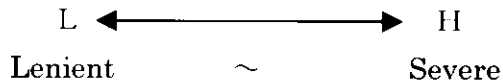

2) Display

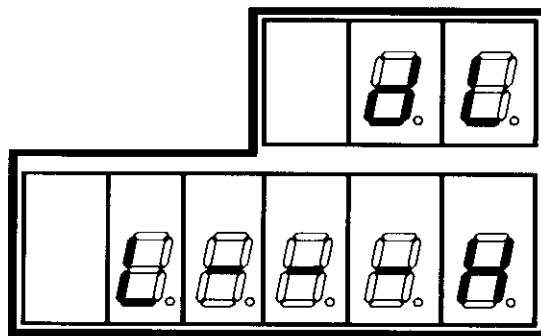

※Selected value blinks

3) Key

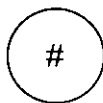

Key . . . A cursor moves in order of

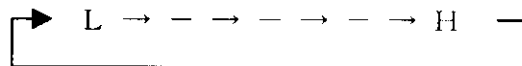

Key . . . Value selected by a cursor becomes new value, then go to No.7 item setup.



Key . . . Value selected by a cursor becomes new value, then go to idle.

⑦ The number of sheets to make reject stacker full.( Reject full )

1) Function

Set the number of Reject full. ( 1 , 1 0 , 2 0 , 3 0 , 4 0 , 5 0 pcs.)

Default value: 2 0

2) Display

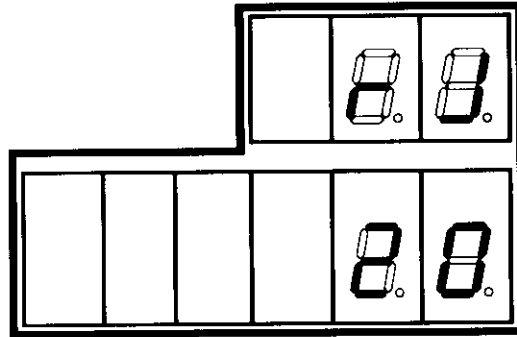

※ Display the number of reject full.

3) Key

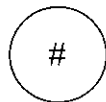

Key . . . A cursor moves in order of



Key . . . Value selected by a cursor becomes new value, then go to No.8 item setup.



Key . . . Value selected by a cursor becomes new value, then go to idle.

⑧ Printer interface ON/OFF

1) Function

Selects whether printer is connected or not. (2 levels)

Default value: OFF

※ When a terminal interface is set to ON, a printer interface is disabled.

2) Display

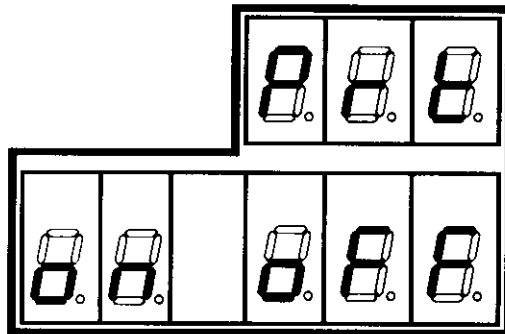

※Selected value blinks

3) Key

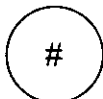

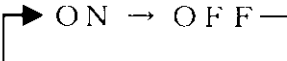
Key . . . A cursor moves in order of 



Key . . . Value selected by a cursor becomes new value, then go to No.9 item setup.



Key . . . Value selected by a cursor becomes new value, then go to idle.

⑨ Baud rate

1) Function

Set the baud rate for an external interface. (4 levels)

Default value: 1 9 2 0 0

Only PC Log simulator function can switch.

Baud rates : 2 4 0 0, 4 8 0 0, 9 6 0 0, 1 9 2 0 0 bps

Functions	Baud rate
PC Log simulator	4 Level
Printer	9 6 0 0 b p s Fixed
Ext. interface	2 4 0 0 b p s Fixed

2) Display

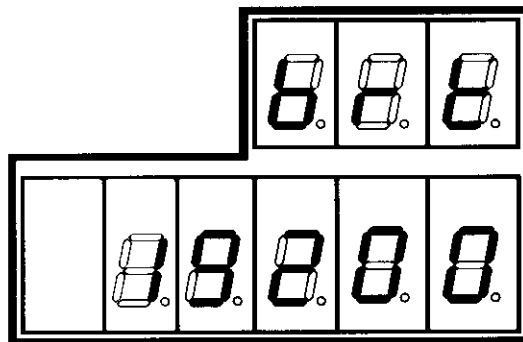

※Selected value blinks

3) Key

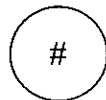

Key . . . A cursor moves in order of

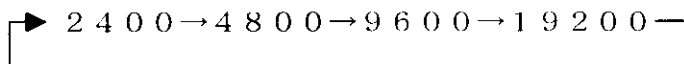

Key . . . Value selected by a cursor becomes new value, then go to idle.



Key . . . Value selected by a cursor becomes new value, then go to idle.

## 5. Instructions for maintenance

### Tools

- Phillips screwdriver (L = 103 mm) • Adjustment driver
- Allen wrench (M3, M4, M5) • Wrench • Ruler (150 mm)
- Digital multi tester • Alcohol • Silicone cloth • thickness gauge

#### 【1】Cleaning sensors

Clean each sensor shown in Fig.1 ~ 3 with a cleaning brush(attached as an accessory).

Warning : Turn off power to the machine before cleaning.

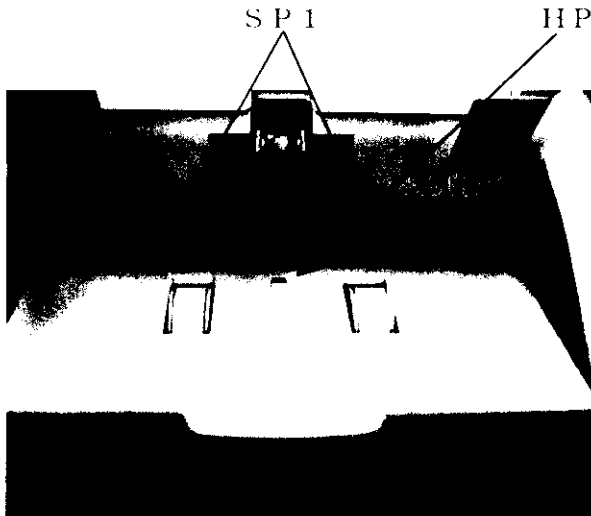

Fig. 1

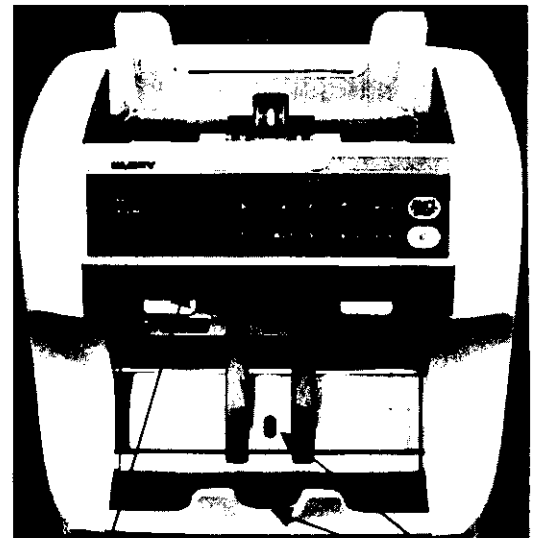

Fig. 2

Reflective sensors

SP 2

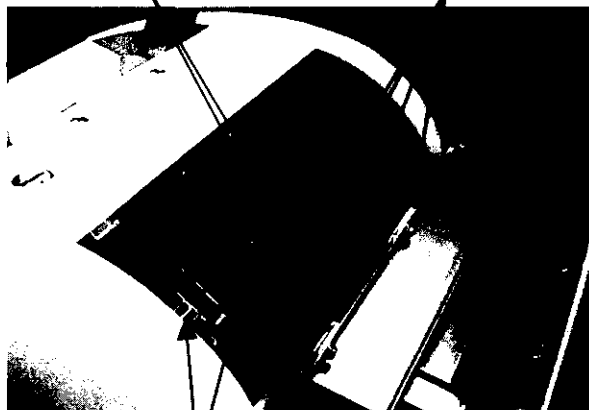

Fig.3

Magnetic heads

## 【 2 】 Cleaning rollers and belts

Check surfaces of all belts and rubbers of feed roller, kicker roller, polling roller, and if they are dirty, clean them with alcohol soaked soft cloth.

Warning) Do not use solvents.

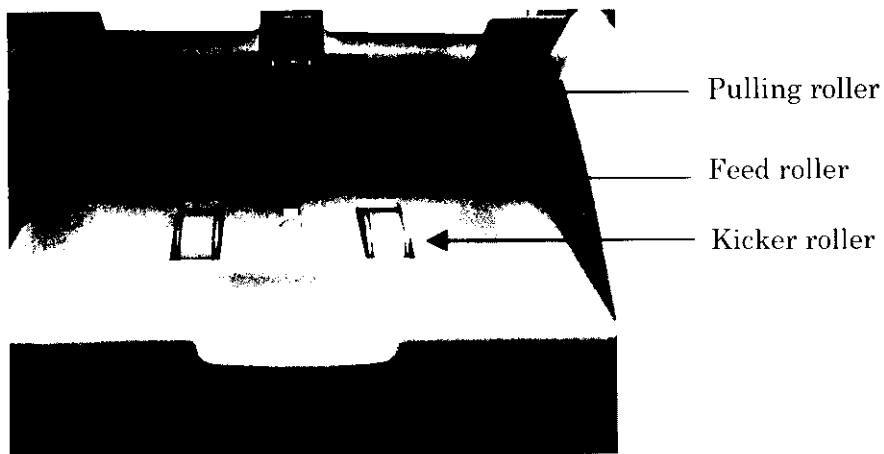

Fig. 4

## 【 3 】 Adjusting gate gap with thickness adjusting screw

In order to count currencies without a jam, it is necessary to adjust a gate thickness, depending upon currencies' condition.

- ① To reduce rejected currencies caused by chained notes.  
Rotate the screw toward "-" or CCW.
- ② To enter currencies smoothly, or to count thick sheets.  
Rotate the screw toward "+" or CW.

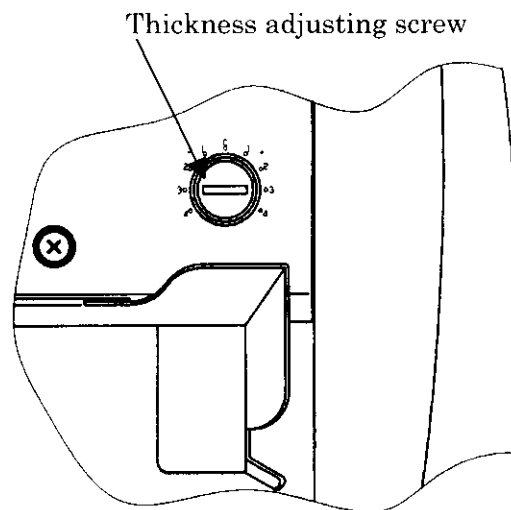

Fig. 5

## 【 4 】 Instruction to remove covers from machine

- ① Left and right covers

Take off screws A (C F 4 × 6 : 4 pcs.) (Fig. 6 ~ 8)

- ② Upper cover

Take off screws B (C B 4 × 10 : 2 pcs.) (Fig. 9)

Take off an auxiliary hopper plate.

③ Front cover

Remove left and right covers by the step ①.

Take off connector (MCN 9) (Fig. 1 0)

Loosen screws C (CRW4 × 8 : 2 pcs.)

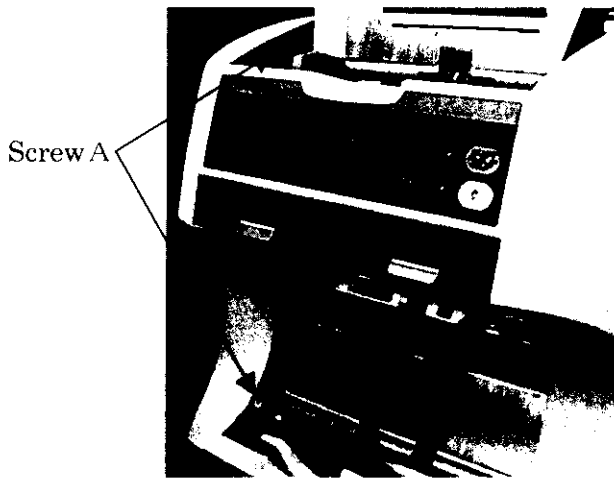

Fig. 6



Fig. 7

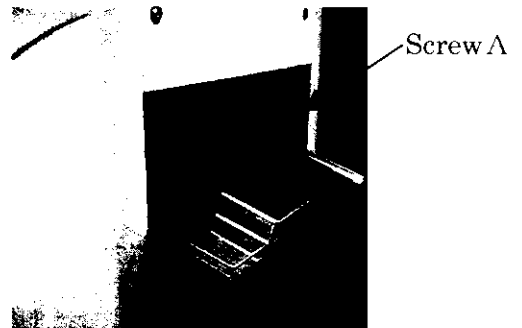

Fig. 8

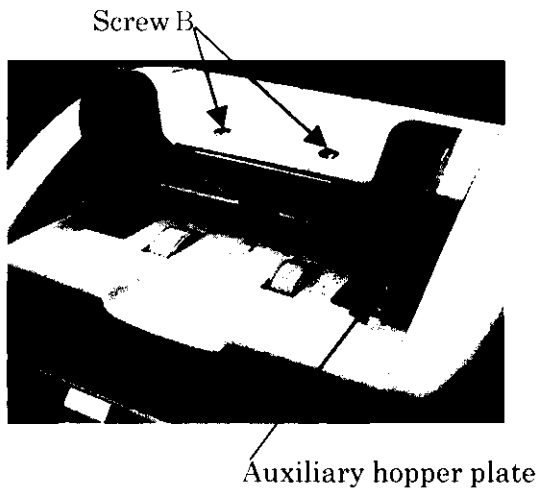

Fig. 9

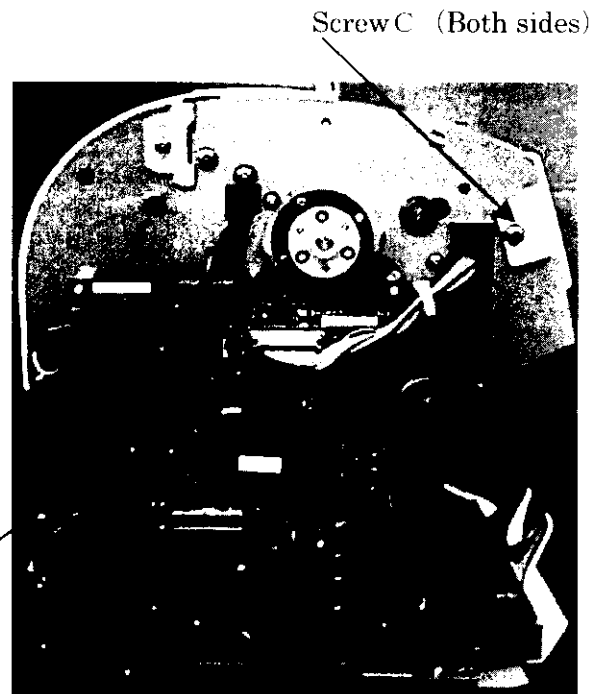

Fig. 1 0

**【 5 】 Instruction to rewrite ROM**

- ① Take off left cover by referring to 【 4 】 ①.
- ② Put new ROM in a ROM writer.
- ③ Switch mini jumpers J1·J2 to Fw side in main board.
- ④ Connect the connector of the ROM writer in MCN16 of main board. (Fig. 1 1)  
(In the case of option spec., MCN 16 have been used already, so remove the connector first, then follow the direction above.)
- ⑤ Turn on power to machine. (A green LED in the ROM writer is lit up.)
- ⑥ Press a start button in the ROM writer. To rewrite ROM.  
(An orange LED in the ROM writer is lit up.)
- ⑦ Completion of rewriting a ROM (when a LED in the ROM writer becomes green.)  
※If there is an error, a LED in the ROM writer becomes red.
- ⑧ Turn off the power.  
(In the case of option, switch mini jumpers J1·J2 to I/F side in main board and bring back MCN16,MCN17 to the original.)
- ⑨ Go to RAS mode and clear RAM and adjust sensors automatically by relevant commands. (See 8. RAS spec.)

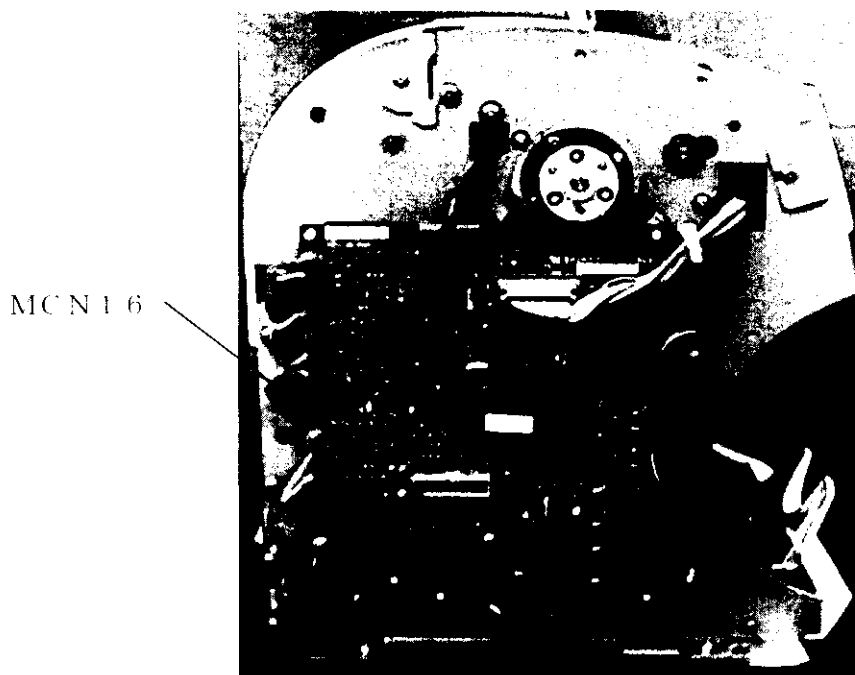

Fig. 1 1

**【 6 】 Instruction to exchange power supply**

- ①Take off left cover by referring to 【 4 】 ①.
- ②Loosen screws D (CRW 3 × 20 : 2 pcs) and pushing plate.
- ③Disconnect connector (MCN19,26) (For option spec. machine, remove MCN24,25)
- ④Take off screws E (CRW 3 × 6 : 2 pcs.) and then remove rear panel (Fig. 1 2)
- ⑤Take off screws F (CRW 3 × 6 : 2 pcs) and get a battery.
- ⑥Replace with a new power supply and reassemble in reverse order.

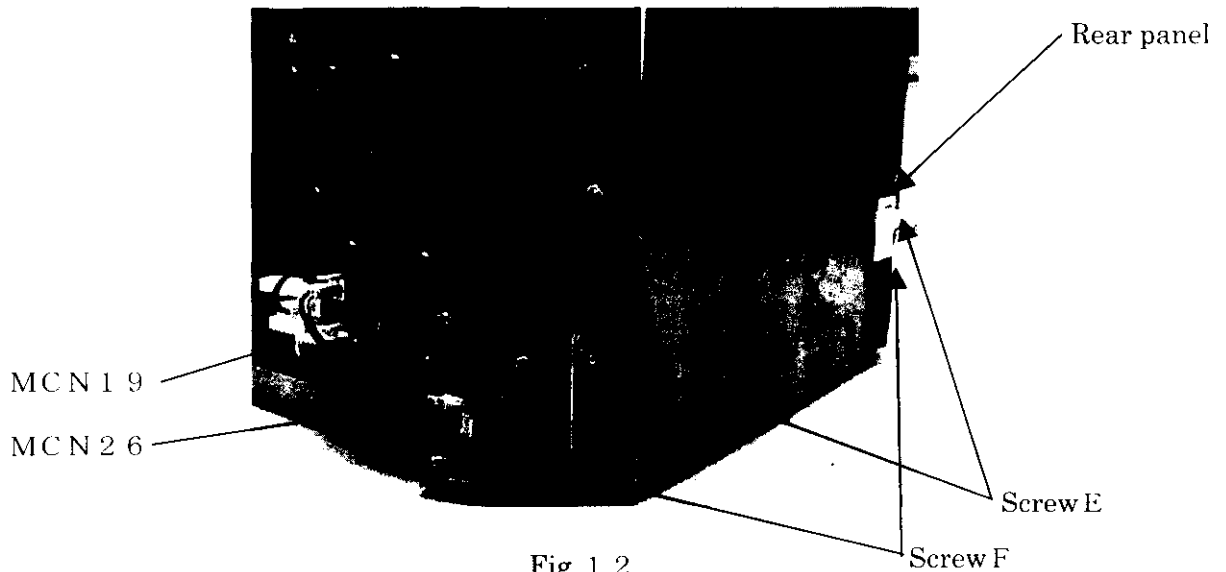

Fig. 1 2

**【 7 】 Instruction to exchange magnetic heads**

- ①Take off left and right covers by referring to 【 4 】 ①
- ②Remove all connectors in the main board and take off the main board.
- ③Take off screws G (CRW 4 × 8 : 2 pcs) and rear door. (Fig. 1 3)
- ④Take off a screw H (CRW 3 × 4 : 1 pc) and an encoder bracket.
- ⑤Take off encoder set.
- ⑥Take screws I (CRW 3 × 6 : 4 pcs) and the guiding plate set 2. (Fig. 1 4)
- ⑦Take off screws J (CRW 3 × 6 : 2 pcs) and the guiding plate (UD) .
- ⑧Take off cable ties. (5 pcs) (Fig. 1 5)
- ⑨Take off screws K (CRW 3 × 1 2 : 2 pcs) and MG ass'y.
- ⑩Exchange MG ass'y and reassemble in reverse order.

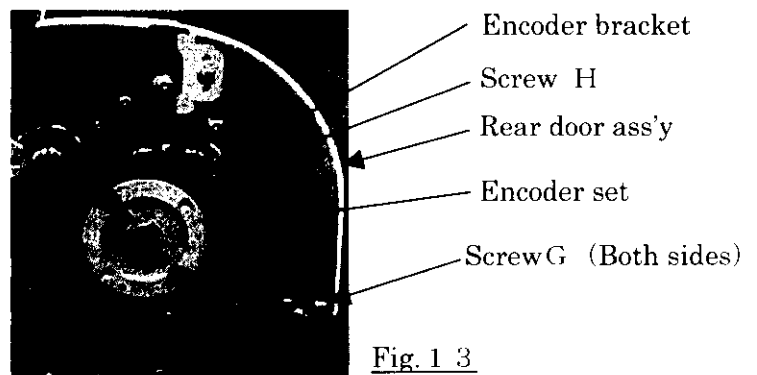
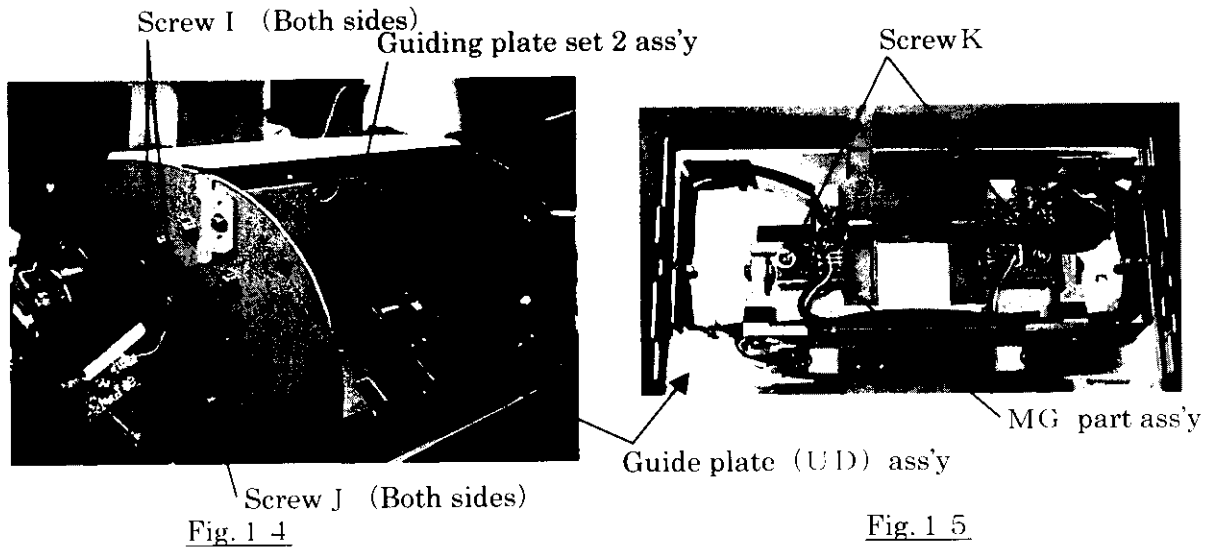

Fig. 1 3



**【 8 】 Instruction to exchange reflection sensor**

~Side of guide plate (UD) ass'y~

- ① Take off the guide plate (UD) ass'y by referring to 【 7 】 ①~⑦.
- ② Take off connector (SCN10) . (Fig. 1 6)
- ③ Take off screw L (CRS 3 × 2 0 : 1 pc) and REF sensor B.
- ④ Exchange REF sensor B and reassemble in reverse order.

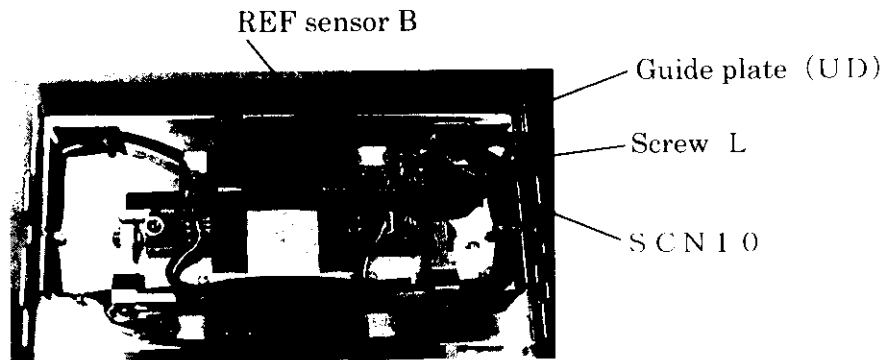

Fig. 1 6

~Side of guide plate set ass'y~

- ① Take off rear door ass'y by referring to 【 7 】 ①~③
- ② Take off screws M (CB 4 × 8 : 6 pcs) and rear cover. (Fig. 1 7, 1 8)
- ③ Take off screws N (CRW 3 × 4 : 5 pcs) and cover set. (Fig. 1 9)
- ④ Remove cable tie. ( 1 pc)
- ⑤ Take off connector (SCN9) (Fig. 2 0)
- ⑥ Take off screw O (CRS 3 × 2 0 : 1 pc) and REF sensor B.
- ⑦ Exchange REF sensor B and reassemble in reverse order.

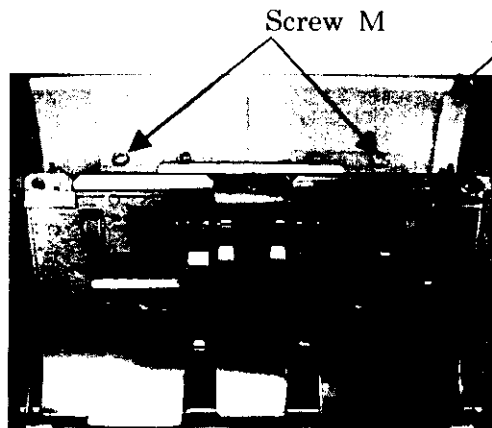

Fig. 1 7

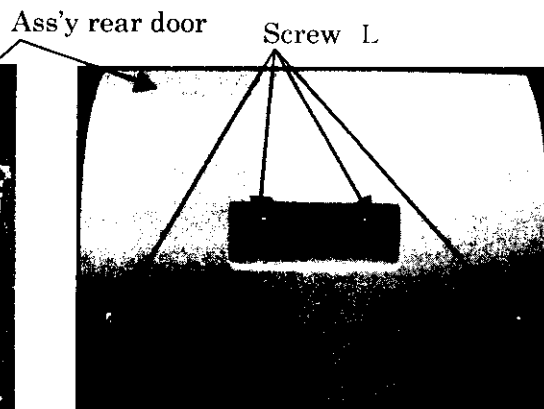

Fig. 1 8

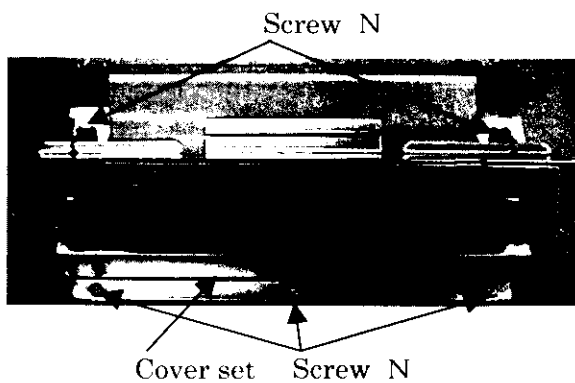

Fig. 1 9

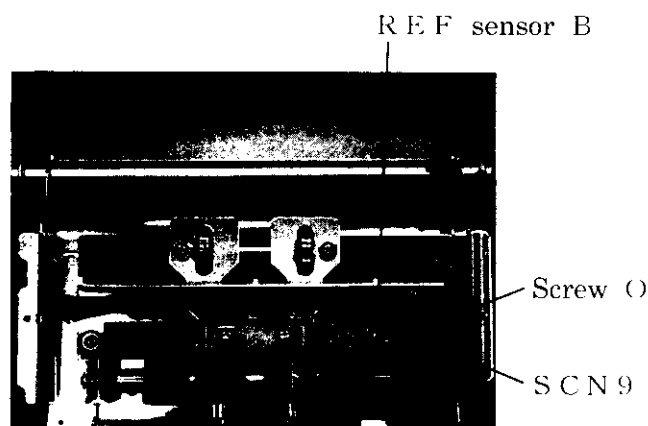

Fig. 2 0

**【 9 】 Instruction to exchange feed rollers**

- ① Take off front cover by referring to 【 4 】 .
- ② Take off screw P (CRW 3 × 6 : 1 pc) and connector bracket. (Fig. 2 1)
- ③ Loosen screws Q (HSS 3 × 3 : 2 pcs) and clutch. (Fig. 2 1)
- ④ Loosen screws R (HSS 3 × 3 : 2 pcs) and brake. (Fig. 2 2)
- ⑤ Loosen a screw S (CRW 4 × 6 : 1 pc) and timing pulley set. (Fig. 2 1)
- ⑥ Take off guide plate (UD) ass'y by referring 【 7 】 ①~⑦.
- ⑦ Take off E-ring. (E - 6 : 1 pc) (Fig. 2 3)
- ⑧ Loosen screws T (HSS 4 × 6 : 2 pcs) and feed roller ass'y.
- ⑨ Take off one-touch shaft stopper, and then a feed roller and a middle roller.
- ⑩ Exchange parts and reassemble in reverse order.

※ 1 When installing feed rollers and kicker rollers, follow the instructions described in 6. 【 2 】 .

※ 2 If necessary, adjust gate thickness and the lateral position of pulling rollers.

(See 6. 【 1 】)

※3 Adjust brake. (See 6. 【3】)

※4 Adjust clutch. (See 6. 【4】)

※5 Adjust timing belt. (See 6. 【5】)

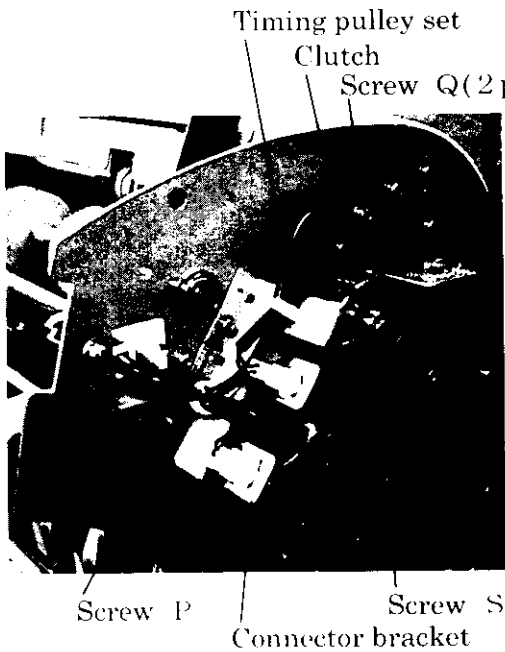

Fig. 2 1

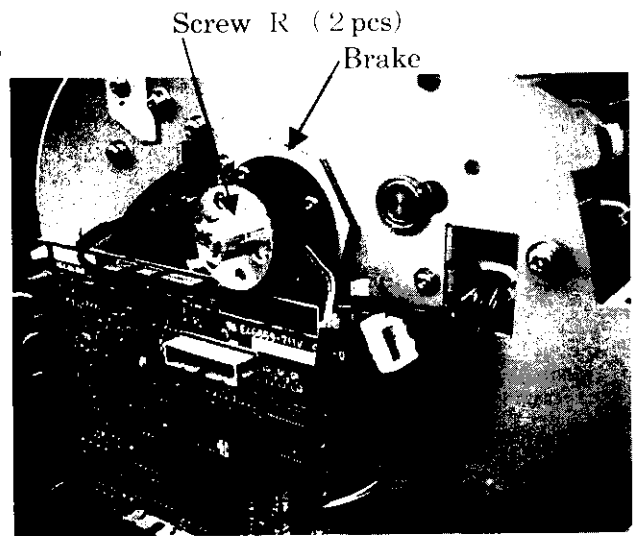

Fig. 2 2

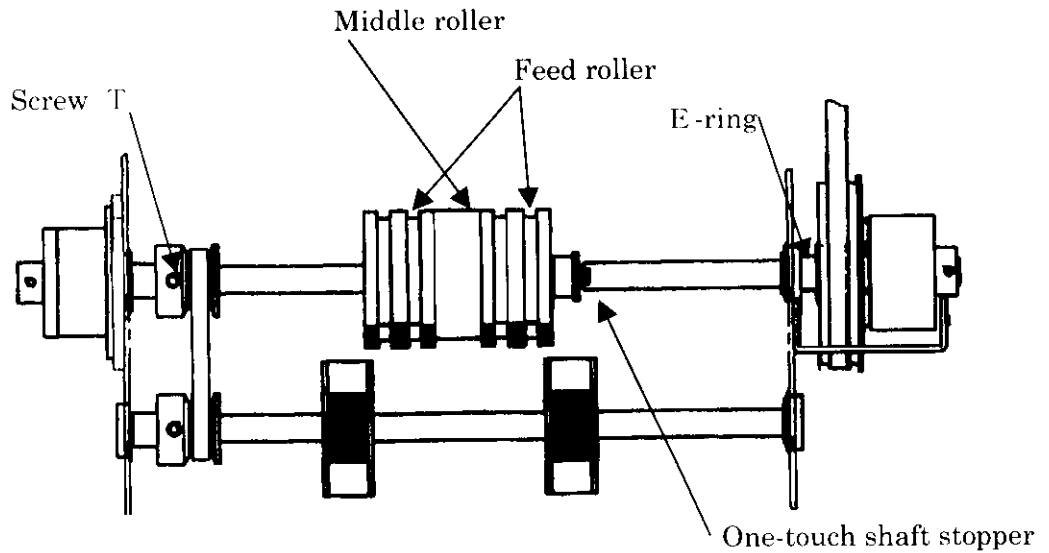
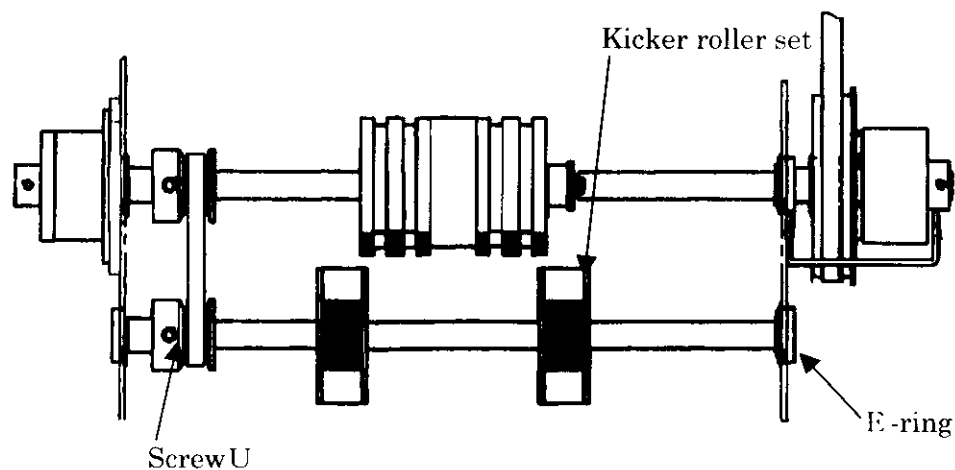

Fig. 2 3

**【 1 0 】 Instruction to exchange kicker rollers**

- ① Take off front cover by referring to **【 4 】** .
- ② Take off an E-ring (E - 6 : 1 pc) (Fig. 2 4)
- ③ Loosen screws U (IIS S 4 × 6 : 2 pcs) and kicker roller set.
- ④ Exchange parts and reassemble in reverse order.

※ When installing feed rollers and kicker rollers, follow the instructions described in 6. **【 2 】** .



**Fig. 2 4**

**【 1 1 】 Instruction to exchange pulling rollers**

- ① Take off upper cover by referring **【 4 】** ②.
- ② Open rear cover.
- ③ Take off screws V (C R W 4 × 8 : 2 pcs) and gate arm. (Fig. 2 5)

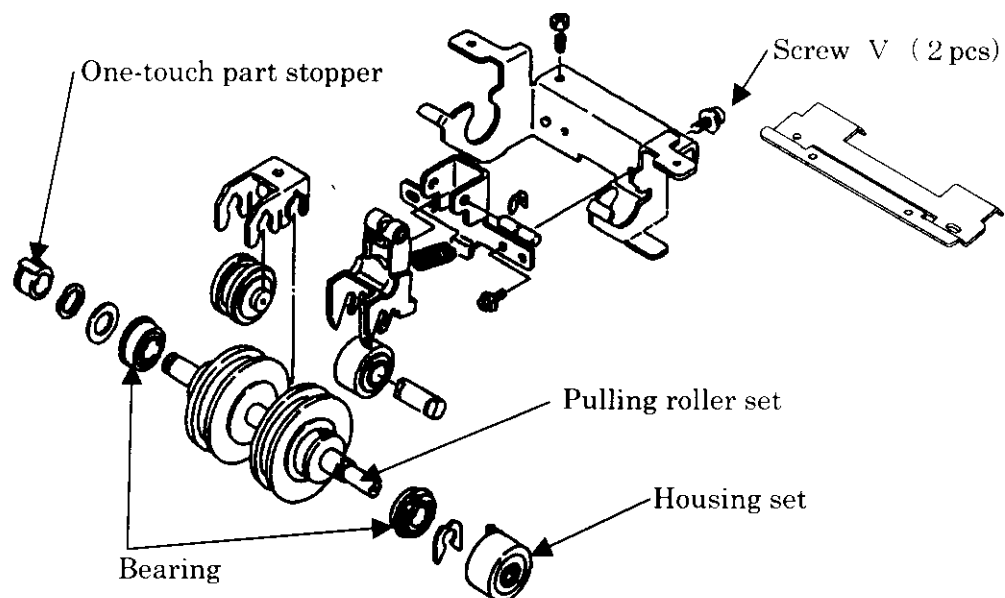

**Fig. 2 5**

- ④ Take off one-touch part stopper, housing set, bearings, and remove pulling roller set from gate arm.

⑤ Exchange parts and reassemble in reverse order.

※ If necessary, adjust gate thickness and lateral position of pulling roller.

(See 6. 【1】)

【1 2】 Instruction to exchange brush rollers

- ① Take off cover set by referring to 【8】 ~ the side of a guide plate set ~ ①~③.
- ② Take off screws W (C R W 3 × 6 : 2 pcs) and plate spring. (Fig. 2 6)
- ③ Take off E-rings (E - 3 : 2 pcs) and brush roller ass'y.
- ④ Take off E-rings (E - 6 : 2 pcs) and rollers and collars (Fig. 2 7)
- ⑤ Pull out parallel pins ( 4 pcs) and remove brush roller set.
- ⑥ Replace parts with new ones and reassemble them in reverse order.

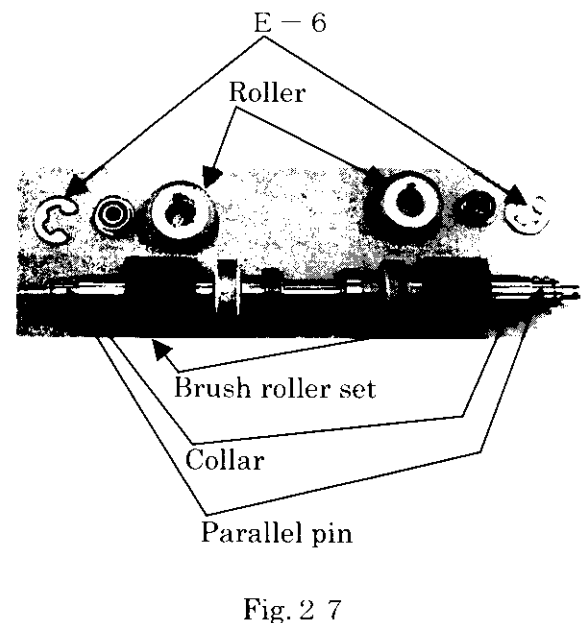
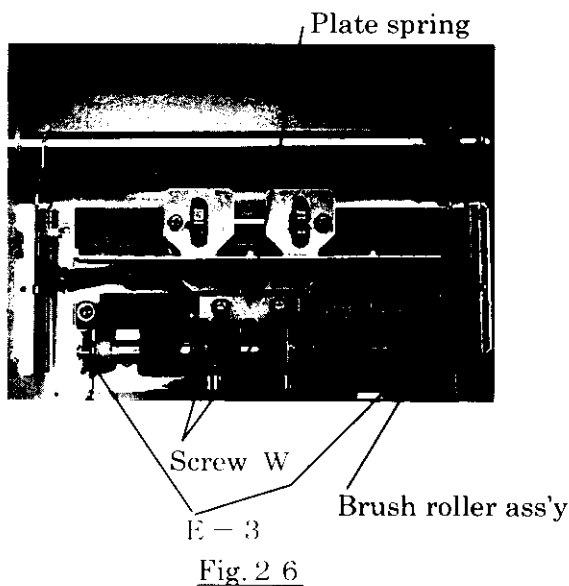

【1 3】 Instruction to exchange main motor

- ① Take off left and right covers by referring to 【4】 ①.
- ② Remove all connectors in main board and take off main board.
- ③ Take off screws X (C R W 3 × 6 : 4 pcs) and Shoot Ass'y.. (Fig. 2 8)
- ④ Loosen screws Y (C R W 4 × 6 : 1 pcs) , and remove Push Nut and a Motor Pulley.
- ⑤ Take off screws Z (C R S 3 × 6 : 3 pcs) and DC Motor.
- ⑥ Exchange the parts and reassemble in reverse order.

※ 1 Adjust timing belt. (See 6. 【5】)

※ Be sure to prevent fin from touching harness coming out of 2 DC motor.

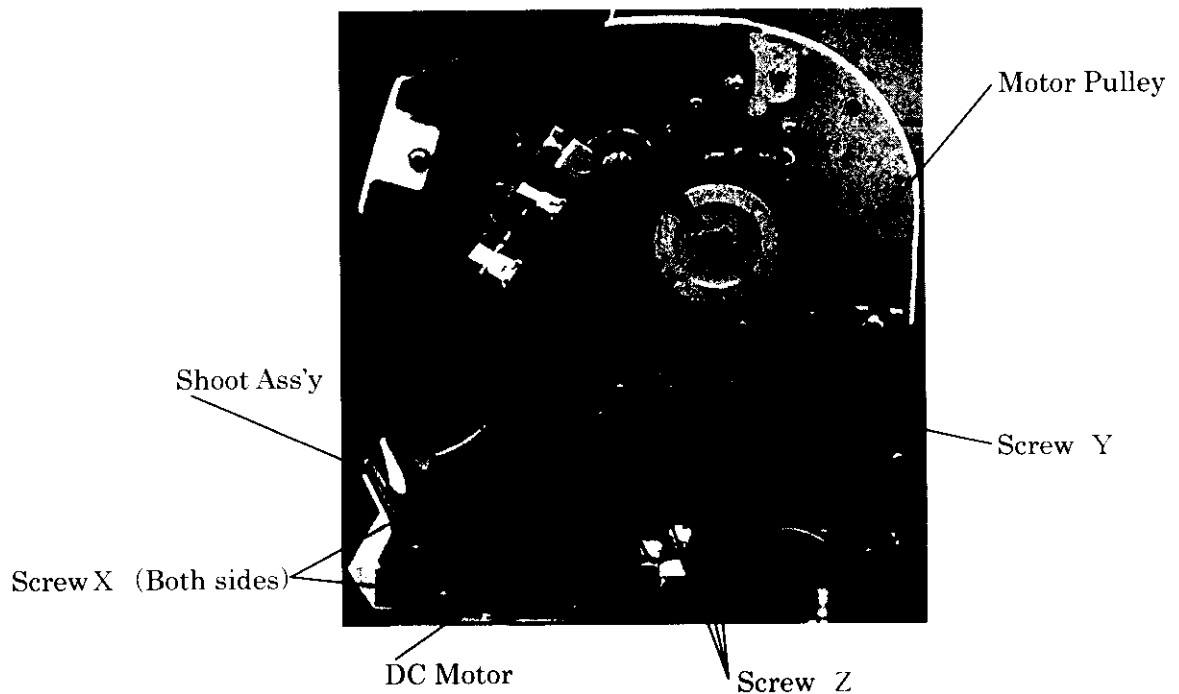

Fig. 2 8

**【 1 4 】 Instruction to exchange solenoids**

① Take off right cover by referring to 【 4 】 ①.

② Take off connector (MCN 2 1) . (Fig. 2 9)

③ Take off screws a (CRW4×6 : 1 pcs) , screws b (CRW3×10 : 1 pcs) and Solenoids Ass'y. (Fig. 2 9, 3 0)

④ Exchange parts and reassemble in reverse order.

※ Adjust Flipper. (See 6. 【 6 】)

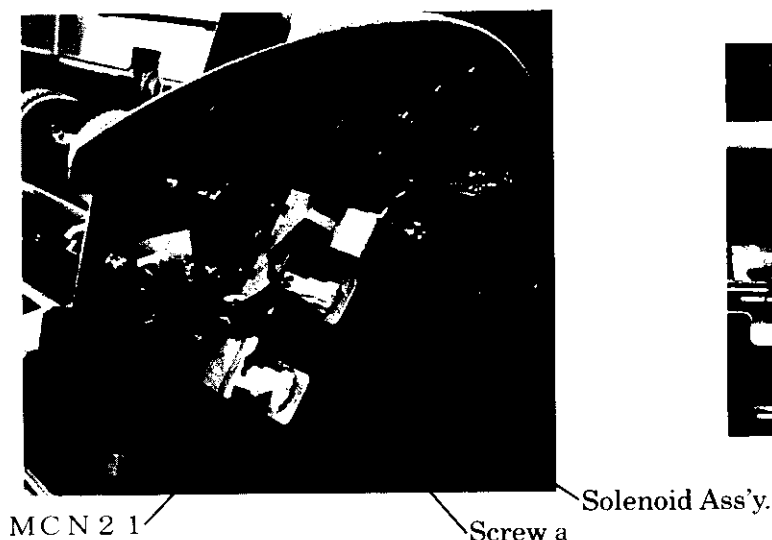

Fig. 2 9

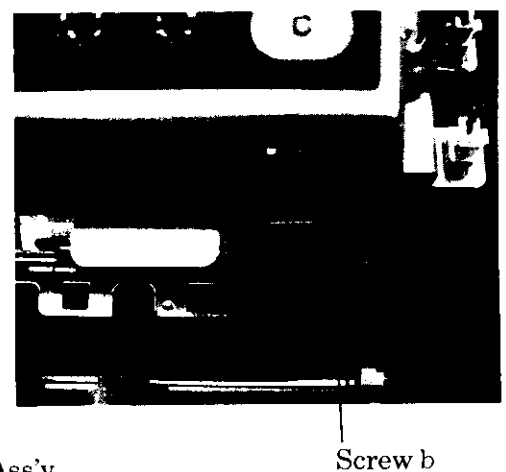

Fig. 3 0

## 6. Adjustment of each part

### 【1】 Adjusting gate

#### ① Installing and adjusting gate arm.

- 1) Tighten a screw temporarily while putting gate arm on the flat surface of gate arm ass'y.

(Fig. 1)

- 2) Move gate arm laterally, and adjust the lateral location of pulling rollers and feed rollers.
- 3) Adjust the lateral location of pulling rollers and feed rollers as shown in Fig. 2.
- 4) Tighten thoroughly a screw A after the adjustment.

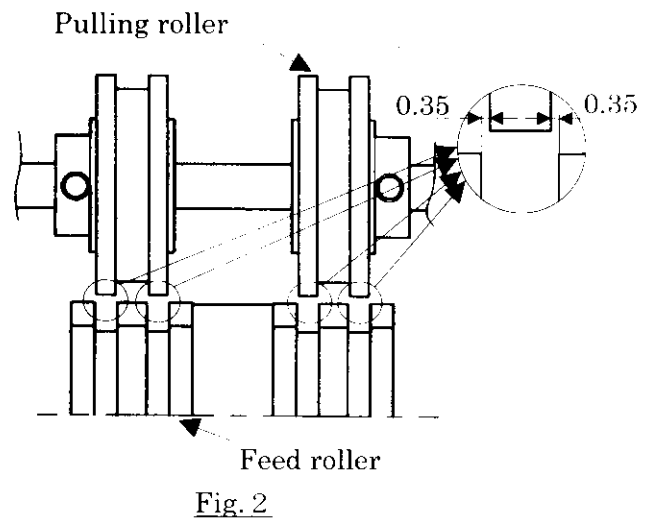
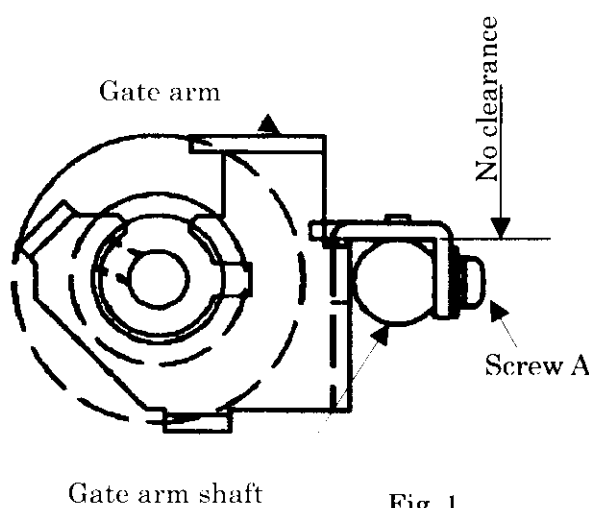

#### ② Adjusting gap between pulling rollers and feed rollers.

- 1) Adjust gap between pulling rollers and feed rollers as shown in Fig. 3, and fix it with screw b.
- 2) If the left and right gaps are not equal, adjust gaps according to ③ (Difference up to 0.01 mm can be considered equal.)

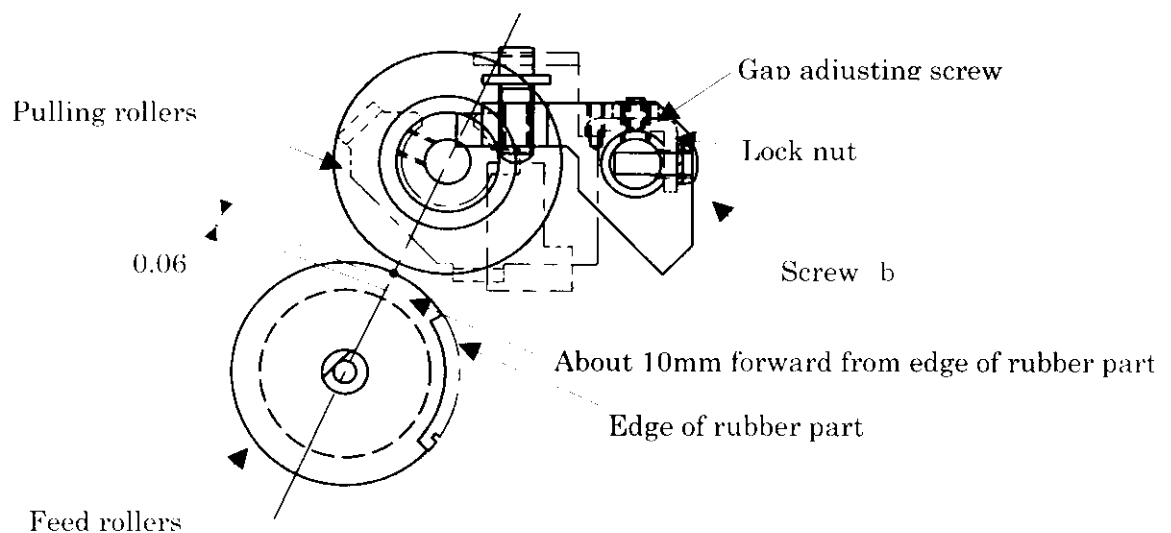

③ Adjusting left and right gaps of gate. (Fig. 3)

- 1) Tighten lightly adjusting screw for left and right gaps.
- 2) Check left and right gaps and adjust (widen) narrower gap by rotating its gap adjusting screw CW.
- 3) If left and right gaps become equal (left gap = right gap  $\pm 0.01$  mm), lock gap adjusting screw with lock nut.

【 2 】 Phase adjustment of kicker rollers and feed rollers.

Position kicker rollers and feed rollers as shown below. Fix the relation between kicker rollers and feed rollers by tightening setscrews of timing pulleys.

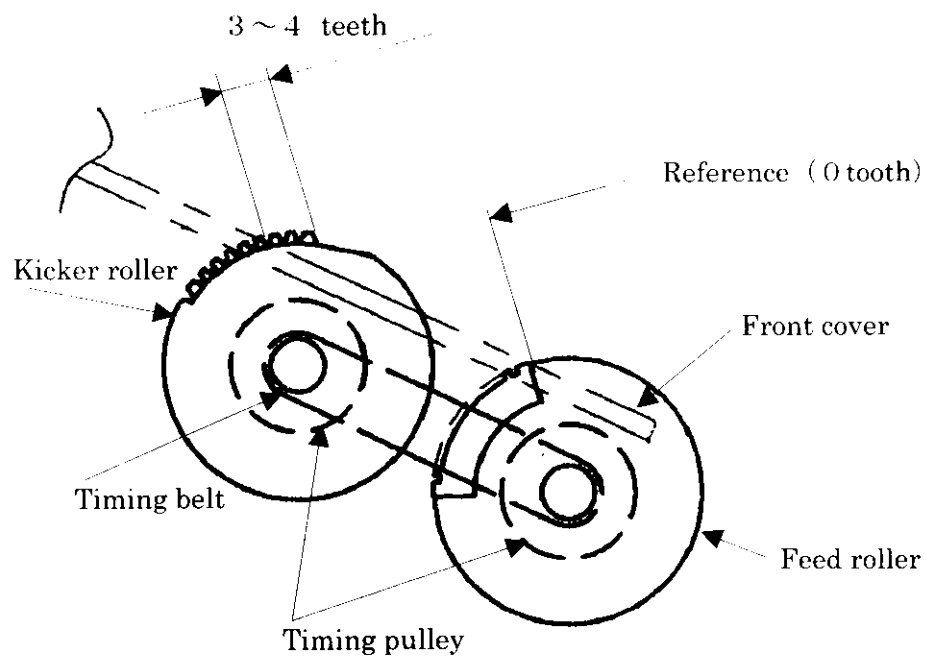

Fig. 4

**【 3 】 Adjusting brake.**

Using a thickness gauge, adjust gap between an armature and lining as shown in Fig.5.

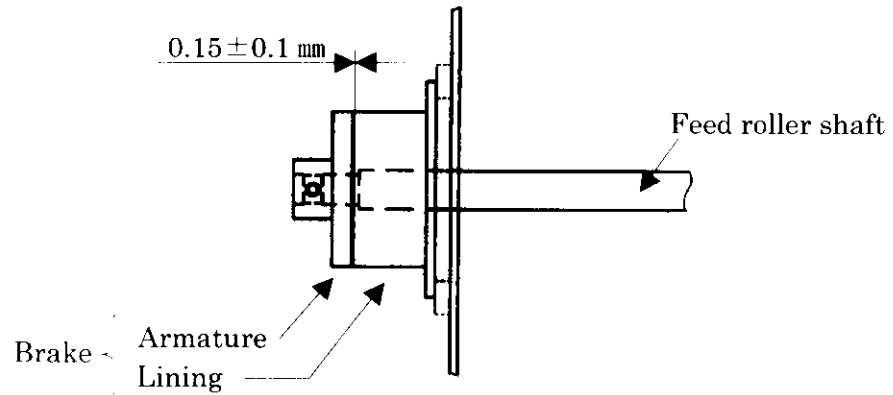

Fig. 5

**【 4 】 Adjusting clutch.**

Install clutch while pushing it toward the direction of the arrow shown.

(Reference value  $A = 0.25 \begin{smallmatrix} +0.25 \\ 0 \end{smallmatrix}$ )

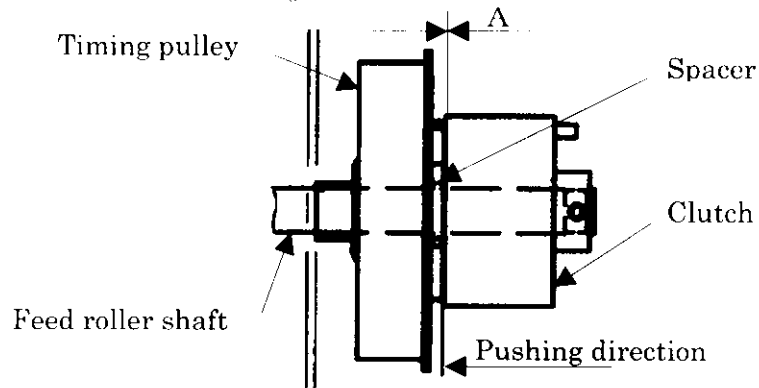

Fig. 6

**【 5 】 Adjusting timing belt.**

Adjust timing belt as shown in Fig.7 by changing the position of idler set.

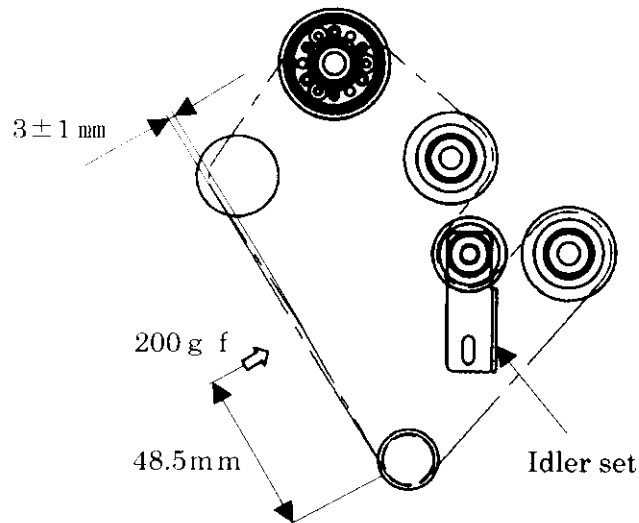
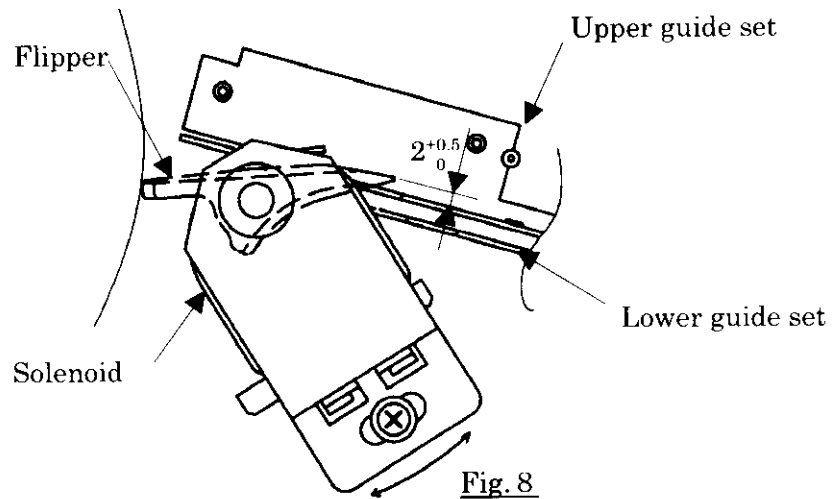

Fig. 7

【 6 】 Adjusting flipper.

Adjust flipper as shown below by moving solenoid bracket and lock it with screw.



【 7 】 Adjusting roller catch.

Adjust roller catch to the value as shown in Fig.9 with lower guide set closed.

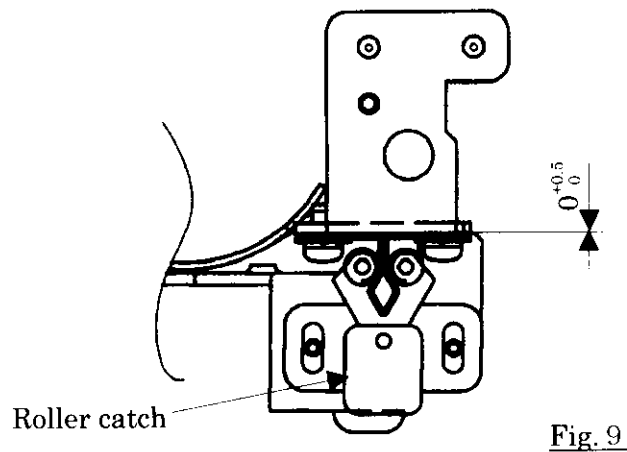

【 8 】 Setup of power supply, sensor, mini-jumpers and switches

① Adjusting sensors (HP, SP 1 L, SP 1 R, SP 2 L, SP 2 R, ST, R J)

Go to RAS mode (See 8. 【 2 】 ①), then adjust sensors automatically.

See 8. 【 6 】 for details of this adjustment.

② Adjusting reflection sensor (REF) .

RAS 02

1) Go to RAS mode (See 8. 【 2 】 ①), then adjust reflection sensor.

2) Set VR1~4 of a main board to the middle position.

3) Display sensors' voltages by referring to 8. 【 6 】

4) Press  $\text{\textcircled{AMT/PCS}}$  key (or  $\text{\textcircled{CALL}}$  key) several times to display sensor "r LF".

5) Adjust VR5 to change A/D value from 0.1 V to 0.0 V.

PLF = VR5 = 0.0  
 PLB = VR6  
 RRF = VR7  
 RRB = VR8

6) In the similar manners to steps 4) ~ 5) , adjust "r Lb", "rrF", "rrb" with VR 6, VR 7, VR 8.

7) Open rear cover and install a dummy paper for adjustment (G-80 GFB) on REF sensor.

8) Press  $\text{\textcircled{CALL}}$  key (or  $\text{\textcircled{AMT/PCS}}$  key) several times to display sensor "r LF".

9) VR 3, VR 4 to make "r LF", "r Lb", "rrF", "rrb"  $3.7 \pm 0.1$  V, adjust VR 1, VR 2.

PLF = VR1 - 3  
 PLB = VR2  
 RRF = VR3  
 RRB = VR4

10) Remove the dummy paper for adjustment.

### 【9】 Sensor layout

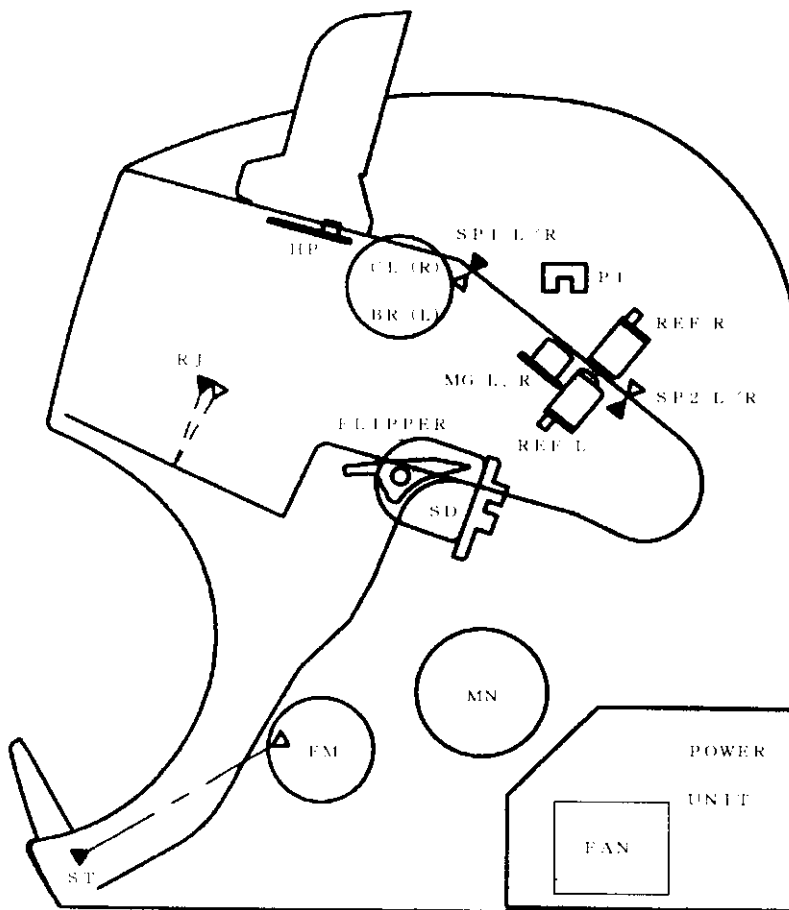

- SP 1 : Photo sensor
- SP 2 : Photo sensor
- ST : Stacker sensor
- HP : Hopper sensor
- R J : Reject sensor
- P I : Photo interrupter
- CL : Clutch
- BR : Brake
- REF : REF sensor
- MG : Magnetic sensor
- SD : Solenoid
- MM : Main motor
- FM : Fin motor
- FAN : DC Fan

▼ Receiver  
 △ Emitter

## 7. Connecting optional parts

### 【1】 Components to be Mounted

Part No.	Description	Quantity
YGFR-10-IB	GFR-S80 I/F Option	1

### 【2】 Setup of mini-jumps and D I P S W

When connecting to the peripherals listed below, set DIP SW, mini jumpers following the respective instructions.

#### ① Connecting printer

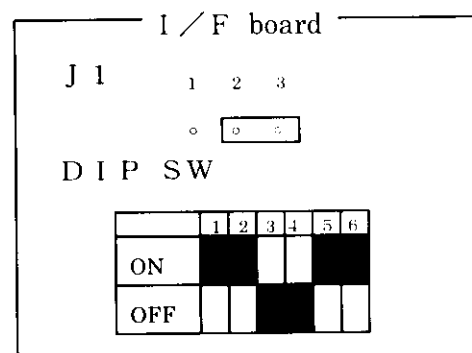
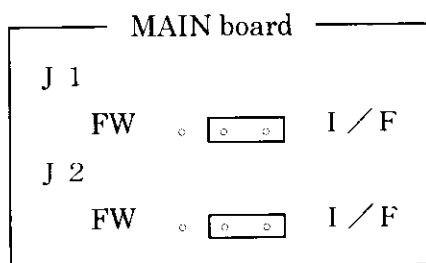

※Use CITIZEN Model IDP3540 or equivalent.

#### ② Connecting terminal (PC or SR700 series)

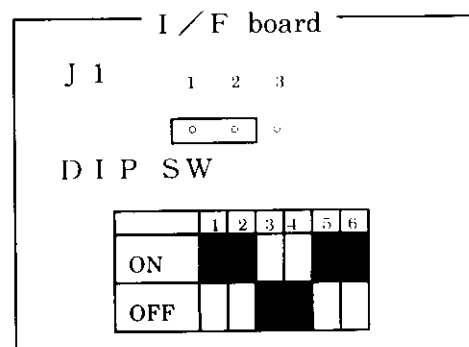
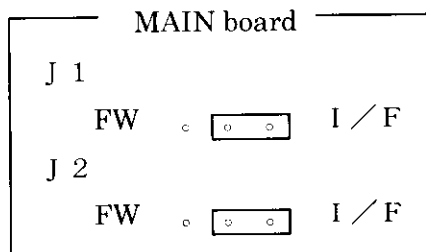

※Setting DIP SW during communications loop check and confirm it with RAS 2 - 0.

**【 3 】 Installation procedure**

- ①Take off left and right covers by referring to 5. **【 4 】** ①
- ②Take off screws b (CRW 3 × 6 : 2pcs) and a Back Panel.
- ③Exchange the parts.
- ④Insert a connector (MCN24,25)
- ⑤Reassemble left and right covers.

## 8. R A S specification

### 【1】 Layout of displays and operation keys

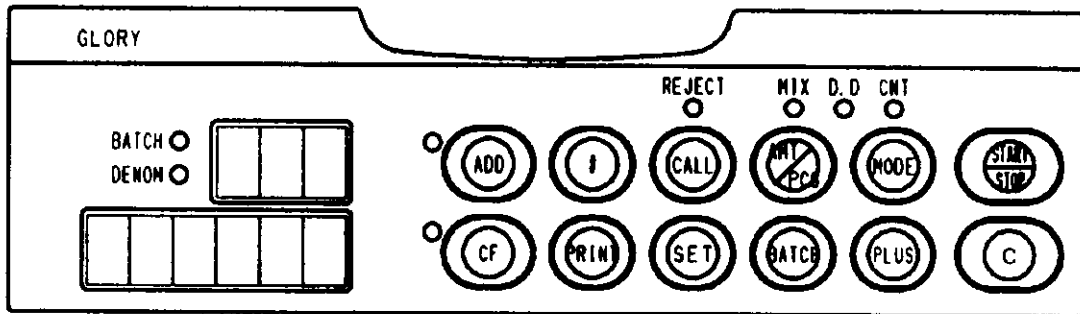

### 【2】 Starting and finishing R A S mode









#### ① How to start RAS mode.

Turn on power while pressing  $\text{ADD} + \text{C}$  keys, then R A S mode is activated, and the machine becomes idle.

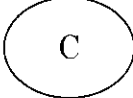
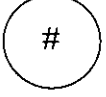
#### ② How to finish RAS mode.

Finish by turning off the power.

### 【 3 】 Operation key functions

- ①  : Switching category of RAS mode
- ②  : Switching more defiled category of RAS mode
- ③  : Cancel
- ④  : Confirmation of each RAS operation
- ⑤  : Beginning each RAS operation
- ⑥  : Incrementing items(data) for each RAS operation  
( When this key is continuously pressed, data will be switched faster)
- ⑦  : Decrementing items(data) for each RAS operation
- ⑧  : Moving a cursor
- ⑨  : Switching contents displayed

**【4】 Input operation for RAS menu**

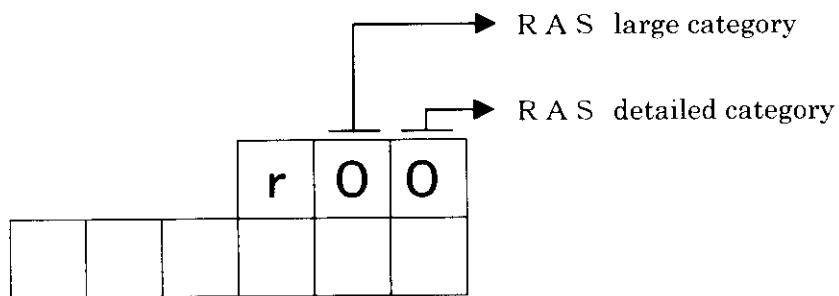

① Contents displayed while large category is input.

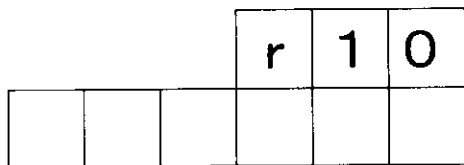

By pressing **BATCH** key RAS mode No. (a large category) can be selected.

② Contents displayed while detailed category is input

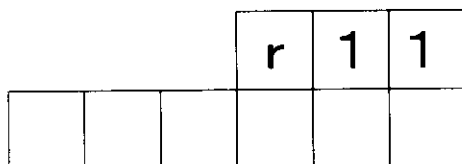

By pressing **PLUS** key RAS mode No. (detailed category) can be selected.

③ Display of starting one of RAS operation

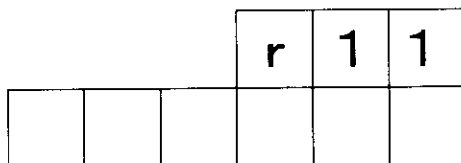

By pressing **START/STOP** key each RAS operation is confirmed.

④ After confirming one RAS operation, the other RAS mode can be selected by

pressing **BATCH**, **PLUS** keys.

【5】 List of RAS items

RAS mode		Mode No.			Contents
		CMND	1stOP	2stOP	
Large class.	Small class.	Large class. Code	Small class. Code	Data	
Sensor Checks	Sensor Adjustment	0	1		Adjusts sensors automatically.
	Display of sensor volt		2	Select sensor	Displays D/A,A/D values of sensors.
	Display of sensor status.		3		Displays the status (blocked or not-blocked).
	Magnetic sensor check		4	Select motor	Displays voltages of magnetic sensors.
Actuator checks	Motor ON/OFF	1	0	Select motor	Continuous operation of main motor and fin motor.
	Aging mode		1	Time	Switches ON/OFF main motor and fin motor for specified time.
	Endurance mode		2		Switches ON/OFF main motor and fin motor.
Display & key checks	Serial comm. loop check	2	0		Checks communication loop with serial communication.
	Key check		1		Lights on/off LEDs.
	LED check		2		Displays the code of pressed key.
	Display ROM version. model		3	Select item displaying	Display ROM version, evaluated No., checksum, machine model.
	Buzzer ON/OFF		4		Turns ON/OFF buzzer.
Data logs display	Total pass number	3	0		Displays total pass number.
	Number of errors		1	Select error code	Displays code and the number of occurring of each error.
	Pass for each denom.		2	Select denom.	Displays number of passed notes for each denomination.
	Number of manual input for each denom.		3	Select denom.	Displays a number of manual input for each denomination.
	Time for main motor ON		4		Displays duration when main motor turns is turned on.



V03-02  
4-02



RAS mode		Mode No.			Contents
		CMND	1stOP	2stOP	
Large class.	Small class.	Large class. code	Small class. code	Data	
backup data Setting	Speed of fin motor	4	0	Select speed	Adjusts the speed of fin motor.
			1		
	Buzzer		2		Turns ON/OFF a buzzer.
			3		
			4		
			5		
			6		
Normal mode	Transmit recognition data	5	0		Set Normal mode. Transmits recognition data.
	Transmit CF data		1	Set	Set normal mode and transmits CF data (CF reject with genuine currency).
Log data clear	Number of errors	9	0		Clears logged number of each errors.
	Number of errors, total pass number		1		Clears number of each errors, total pass number duration when main motor is turned on.
	Default value set		2	Set	Set backup log data as default values.
	Total clear		3		Executes RAS91,92 at once.

9 9 START RETURNS TO REG OPER.

## 【6】 R A S O p e r a t i n g S p e c i f i c a t i o n s

Large (CMND)	Small (1stOP)	Data (2ndOP)	Contents	Processes												
0	1		Sensor adjustment	Adjusts all sensors.												
<p><b>Details:</b></p> <ul style="list-style-type: none"> <li>• Adjusts all sensors. (HP,SP1(L,R),SP2(L,R),ST,RJ)</li> <li>• Displays normal/abnormal for each sensor after adjusting all sensors.</li> <li>• If the adjustment is completed normally, store their D/A values to backup areas.</li> </ul>																
<b>Operations</b>			<b>Displays</b>													
<p>(1) At (Disp.1)</p> <ul style="list-style-type: none"> <li>• Pressing <span style="border: 1px solid black; border-radius: 50%; padding: 2px 5px; display: inline-block; text-align: center;">START STOP</span> key starts processing. ( → Disp.2)</li> </ul>			<p>(Disp.1) Idling (After entering commands)</p> <table style="margin-left: auto; margin-right: auto; border-collapse: collapse;"> <tr> <td style="border: 1px solid black; width: 20px; height: 20px;"></td> <td style="border: 1px solid black; width: 20px; height: 20px;"></td> <td style="border: 1px solid black; width: 20px; height: 20px;"></td> <td style="border: 1px solid black; width: 20px; height: 20px; text-align: center;">r</td> <td style="border: 1px solid black; width: 20px; height: 20px; text-align: center;">0</td> <td style="border: 1px solid black; width: 20px; height: 20px; text-align: center;">1</td> </tr> </table>					r	0	1						
			r	0	1											
<p>(2) At (Disp.2)</p> <ul style="list-style-type: none"> <li>• Normal completion ( → Disp.3)</li> <li>• Abnormal completion ( → Disp.4)</li> </ul>			<p>(Disp.2) Processing</p> <table style="margin-left: auto; margin-right: auto; border-collapse: collapse;"> <tr> <td style="border: 1px solid black; width: 20px; height: 20px; text-align: center;">-</td> <td style="border: 1px solid black; width: 20px; height: 20px; text-align: center;">-</td> <td style="border: 1px solid black; width: 20px; height: 20px; text-align: center;">-</td> <td style="border: 1px solid black; width: 20px; height: 20px; text-align: center;">-</td> <td style="border: 1px solid black; width: 20px; height: 20px; text-align: center;">-</td> <td style="border: 1px solid black; width: 20px; height: 20px; text-align: center;">-</td> </tr> </table> <p style="text-align: center;">Sensor No1~6 is being adjusted</p> <div style="text-align: center; margin: 10px 0;"> </div> <table style="margin-left: auto; margin-right: auto; border-collapse: collapse;"> <tr> <td style="border: 1px solid black; width: 20px; height: 20px; text-align: center;">-</td> <td style="border: 1px solid black; width: 20px; height: 20px;"></td> <td style="border: 1px solid black; width: 20px; height: 20px;"></td> <td style="border: 1px solid black; width: 20px; height: 20px; text-align: center;">r</td> <td style="border: 1px solid black; width: 20px; height: 20px; text-align: center;">0</td> <td style="border: 1px solid black; width: 20px; height: 20px; text-align: center;">1</td> </tr> </table> <p style="text-align: center;">Sensor No7 is being adjusted</p>		-	-	-	-	-	-	-			r	0	1
-	-	-	-	-	-											
-			r	0	1											
<p>(3) At (Disp.3)</p> <ul style="list-style-type: none"> <li>• Waiting command inputs.</li> </ul>			<p>(Disp.3) Normal completion</p> <table style="margin-left: auto; margin-right: auto; border-collapse: collapse;"> <tr> <td style="border: 1px solid black; width: 20px; height: 20px;"></td> <td style="border: 1px solid black; width: 20px; height: 20px;"></td> <td style="border: 1px solid black; width: 20px; height: 20px; text-align: center;">g</td> <td style="border: 1px solid black; width: 20px; height: 20px; text-align: center;">o</td> <td style="border: 1px solid black; width: 20px; height: 20px; text-align: center;">o</td> <td style="border: 1px solid black; width: 20px; height: 20px; text-align: center;">d</td> </tr> </table>				g	o	o	d						
		g	o	o	d											



Operations	Displays																																								
<p>(4) At (Disp.4)</p> <ul style="list-style-type: none"> <li>Pressing  key switches the display of sensors.</li> </ul> <p>① SensorNo1~6 <math>\longleftrightarrow</math> ② SensorNo7</p> <ul style="list-style-type: none"> <li>Pressing  key switches the display of sensors.</li> </ul> <p>① SensorNo1~6 <math>\longleftrightarrow</math> ② SensorNo7</p> <table border="1" data-bbox="341 858 760 1207"> <thead> <tr> <th>SensorNo</th> <th>Sensor name</th> </tr> </thead> <tbody> <tr> <td>1</td> <td>HP</td> </tr> <tr> <td>2</td> <td>SP1(L)</td> </tr> <tr> <td>3</td> <td>SP1(R)</td> </tr> <tr> <td>4</td> <td>SP2(L)</td> </tr> <tr> <td>5</td> <td>SP2(R)</td> </tr> <tr> <td>6</td> <td>ST</td> </tr> <tr> <td>7</td> <td>RJ</td> </tr> </tbody> </table>	SensorNo	Sensor name	1	HP	2	SP1(L)	3	SP1(R)	4	SP2(L)	5	SP2(R)	6	ST	7	RJ	<p>(Disp.4-①) Abnormal(SensorNo1~6)</p> <table border="1" data-bbox="921 355 1309 485"> <tr> <td></td> <td></td> <td></td> <td>r</td> <td>0</td> <td>1</td> </tr> <tr> <td>-</td> <td>-</td> <td>-</td> <td>4</td> <td>-</td> <td>-</td> </tr> </table> <p style="text-align: center;">Sensor No Sensor 4(SP2(L)) is abnormal.</p> <p>(Disp.4-②) Abnormal(SensorNo7)</p> <table border="1" data-bbox="921 700 1309 830"> <tr> <td></td> <td></td> <td></td> <td></td> <td></td> <td></td> </tr> <tr> <td>7</td> <td></td> <td></td> <td></td> <td></td> <td></td> </tr> </table> <p style="text-align: center;">Sensor No Sensor 7(RJ) is abnormal.</p>				r	0	1	-	-	-	4	-	-							7					
SensorNo	Sensor name																																								
1	HP																																								
2	SP1(L)																																								
3	SP1(R)																																								
4	SP2(L)																																								
5	SP2(R)																																								
6	ST																																								
7	RJ																																								
			r	0	1																																				
-	-	-	4	-	-																																				
7																																									

Large (CMND)	Small (1stOP)	Data (2ndOP)	Contents	Processes																																																				
0	2		Display of sensor voltages	Displays sensor's D/A output value and A/D input value.																																																				
<b>Details:</b> <ul style="list-style-type: none"> <li>Displays sensor's D/A output value and A/D input value in real time.</li> <li>Sensors displaying (HP, SP1 (L,R), SP2 (L,R), ST, RJ, REF_L (F,B), REF_R (F,B))</li> </ul>																																																								
<b>Operations</b>			<b>Displays</b>																																																					
<p>(1) At (Disp.1)</p> <ul style="list-style-type: none"> <li>Pressing  key starts processing. (→ Fig.2)</li> </ul> <p>(2) At (Disp.2)</p> <ul style="list-style-type: none"> <li>Pressing  key switches the display of sensors in order shown below.</li> </ul> <p>Display of sensors  HP → S1L → S1R → 2LA → 2Lb → 2rA  ↑ ↓  rrb ← rrF ← rLb ← rLF ← RJ ← St ← 2rb</p> <ul style="list-style-type: none"> <li>Pressing  key switches the display of sensors in order shown below.</li> </ul> <p>Display of sensors  HP ← S1L ← S1R ← 2LA ← 2Lb ← 2rA  ↓ ↑  rrb → rrF → rLb → rLF → RJ → St → 2rb</p>			<p>(Disp. 1) Idling ( After inputting commands)</p> <table border="1" style="margin-left: auto; margin-right: auto;"> <tr> <td></td><td></td><td></td><td>r</td><td>0</td><td>2</td> </tr> <tr> <td></td><td></td><td></td><td></td><td></td><td></td> </tr> </table> <p>(Disp. 2 - ①) Displays voltages of sensors</p> <p style="text-align: center;">D/A value</p> <table border="1" style="margin-left: auto; margin-right: auto;"> <tr> <td></td><td></td><td></td><td>5.</td><td>0</td><td>v</td> </tr> <tr> <td>H</td><td>P</td><td></td><td>5.</td><td>0</td><td>v</td> </tr> </table> <p>Sensor name    A/D value</p> <table border="1" style="margin-left: auto; margin-right: auto;"> <thead> <tr> <th>Display</th> <th>Sensor name</th> </tr> </thead> <tbody> <tr><td>HP</td><td>HP</td></tr> <tr><td>S1L</td><td>SP1 (L)</td></tr> <tr><td>S1r</td><td>SP1 (R)</td></tr> <tr><td>2LA</td><td>SP2 (L)</td></tr> <tr><td>2Lb</td><td>SP2 (L)</td></tr> <tr><td>2rA</td><td>SP2 (R)</td></tr> <tr><td>2rb</td><td>SP2 (R)</td></tr> <tr><td>St</td><td>ST</td></tr> <tr><td>rJ</td><td>RJ</td></tr> <tr><td>rLF</td><td>REF_L (F)</td></tr> <tr><td>rLb</td><td>REF_L (B)</td></tr> <tr><td>rrF</td><td>REF_R (F)</td></tr> <tr><td>rrB</td><td>REF_R (B)</td></tr> </tbody> </table> <p style="text-align: right;">F : inside B : outside</p>					r	0	2										5.	0	v	H	P		5.	0	v	Display	Sensor name	HP	HP	S1L	SP1 (L)	S1r	SP1 (R)	2LA	SP2 (L)	2Lb	SP2 (L)	2rA	SP2 (R)	2rb	SP2 (R)	St	ST	rJ	RJ	rLF	REF_L (F)	rLb	REF_L (B)	rrF	REF_R (F)	rrB	REF_R (B)
			r	0	2																																																			
			5.	0	v																																																			
H	P		5.	0	v																																																			
Display	Sensor name																																																							
HP	HP																																																							
S1L	SP1 (L)																																																							
S1r	SP1 (R)																																																							
2LA	SP2 (L)																																																							
2Lb	SP2 (L)																																																							
2rA	SP2 (R)																																																							
2rb	SP2 (R)																																																							
St	ST																																																							
rJ	RJ																																																							
rLF	REF_L (F)																																																							
rLb	REF_L (B)																																																							
rrF	REF_R (F)																																																							
rrB	REF_R (B)																																																							

Large (CMND)	Small (1stOP)	Data (2ndOP)	Contents	Processes
0	3		Display of the status of sensors	Displays the status if sensors are blocked or not blocked.

Details:





- Displays the status if sensors are blocked or not blocked in real time.
- Sensors displaying (HP, SP1 (L,R), SP2 (L,R), ST, RJ)

Operations	Displays																																																				
<p>(1) At (Disp.1)</p> <ul style="list-style-type: none"> <li>• Pressing  key starts processing. (→ Disp.2)</li> </ul> <table border="1" data-bbox="363 836 780 1168"> <thead> <tr> <th>Sensor No</th> <th>Sensor name</th> </tr> </thead> <tbody> <tr><td>1</td><td>HP</td></tr> <tr><td>2</td><td>SP1 (L)</td></tr> <tr><td>3</td><td>SP1 (R)</td></tr> <tr><td>4</td><td>SP2 (L)</td></tr> <tr><td>5</td><td>SP2 (R)</td></tr> <tr><td>6</td><td>ST</td></tr> <tr><td>7</td><td>RJ</td></tr> </tbody> </table> <p>(2) At (Disp.2)</p> <ul style="list-style-type: none"> <li>• Pressing  key switches the display of sensors.</li> </ul> <p>①SensorNo1~6 ↔ ②SensorNo7</p> <ul style="list-style-type: none"> <li>• Pressing  key switches the display of sensors.</li> </ul> <p>①SensorNo1~6 ↔ ②SensorNo7</p>	Sensor No	Sensor name	1	HP	2	SP1 (L)	3	SP1 (R)	4	SP2 (L)	5	SP2 (R)	6	ST	7	RJ	<p>(Disp.1) Idling (After inputting commands)</p> <table border="1" data-bbox="932 750 1317 879"> <tr><td></td><td></td><td></td><td>r</td><td>0</td><td>3</td></tr> <tr><td></td><td></td><td></td><td></td><td></td><td></td></tr> </table> <p>(Disp.2-①) Displays status of sensors (SensorNo1~6)</p> <ul style="list-style-type: none"> <li>• Displays sensors No1~6.</li> <li>• Displays sensor No when it's blocked.</li> <li>• Display “-“ when it's not blocked.</li> </ul> <table border="1" data-bbox="917 1168 1301 1304"> <tr><td></td><td></td><td></td><td>r</td><td>0</td><td>3</td></tr> <tr><td>1</td><td>-</td><td>-</td><td>-</td><td>-</td><td>6</td></tr> </table> <p>SensorNo Sensor1 (HP), Sensor6 (ST) are shaded.</p> <p>(Disp.2-②) Displays status of sensors (SensorNo7)</p> <ul style="list-style-type: none"> <li>• Displays sensor No7.</li> <li>• Displays sensor No when it's blocked.</li> <li>• Display “-“ when it's not blocked.</li> </ul> <table border="1" data-bbox="943 1698 1329 1832"> <tr><td></td><td></td><td></td><td>r</td><td>0</td><td>3</td></tr> <tr><td>7</td><td></td><td></td><td></td><td></td><td></td></tr> </table> <p>SensorNo Sensor7 (RJ) is blocked.</p>				r	0	3										r	0	3	1	-	-	-	-	6				r	0	3	7					
Sensor No	Sensor name																																																				
1	HP																																																				
2	SP1 (L)																																																				
3	SP1 (R)																																																				
4	SP2 (L)																																																				
5	SP2 (R)																																																				
6	ST																																																				
7	RJ																																																				
			r	0	3																																																
			r	0	3																																																
1	-	-	-	-	6																																																
			r	0	3																																																
7																																																					

Large (CMND)	Small (1stOP)	Data (2ndOP)	Contents	Processes
0	4	Select motor	Magnetic sensor check	Displays voltages of magnetic sensors.

**Details:**

- Turns on motor and displays voltage of magnetic sensor in real time.







Operations	Displays																																																																																																						
<p>(1) At (Disp.1)</p> <ul style="list-style-type: none"> <li>• Pressing  key starts processing. (→ Disp.2)</li> </ul> <p>(2) At (Disp.2)</p> <ul style="list-style-type: none"> <li>• Pressing  key switches motors running in order.</li> <p style="text-align: center;">ALL ↔ FEd</p> <li>• Pressing  key switches motors running in order.</li> <p style="text-align: center;">ALL ↔ FEd</p> <li>• Pressing  key turns on the motors. (→ Disp.3)</li> </ul> <p>(3) At (Disp.3)</p> <ul style="list-style-type: none"> <li>• Pressing  key turns on the motors. (→ Disp.2)</li> <li>• Disabled to enter The other RAS command.</li> </ul>	<p>(Disp. 1 ) Idling ( After inputting commands)</p> <table border="1" style="margin-left: auto; margin-right: auto;"> <tr> <td></td><td></td><td></td><td>r</td><td>0</td><td>5</td> </tr> <tr> <td></td><td></td><td></td><td></td><td></td><td></td> </tr> </table> <p>(Disp.2) When motor is stopped.</p> <table border="1" style="margin-left: auto; margin-right: auto;"> <tr> <td colspan="6"></td> <td colspan="3" style="text-align: center;">Motor name</td> </tr> <tr> <td></td><td></td><td></td><td></td><td>A</td><td>L</td><td>L</td> <td colspan="3"></td> </tr> <tr> <td></td><td></td><td></td><td></td><td>O</td><td>F</td><td>F</td> <td colspan="3"></td> </tr> <tr> <td colspan="6"></td> <td colspan="3" style="text-align: center;">ON/OFF status</td> </tr> </table> <table border="1" style="margin-left: auto; margin-right: auto;"> <thead> <tr> <th>Display</th> <th>Motor name</th> </tr> </thead> <tbody> <tr> <td>ALL</td> <td>Main motor, Fin motor, and clutch</td> </tr> <tr> <td>FEd</td> <td>Main motor</td> </tr> </tbody> </table> <p>(Disp.3) While motor is turning and voltage of magnetic sensor is displayed.</p> <ul style="list-style-type: none"> <li>• Voltages are expressed in Hex system.</li> </ul> <table border="1" style="margin-left: auto; margin-right: auto;"> <tr> <td colspan="6"></td> <td colspan="3" style="text-align: center;">Motor name</td> </tr> <tr> <td></td><td></td><td></td><td></td><td>A</td><td>L</td><td>L</td> <td colspan="3"></td> </tr> <tr> <td>L</td><td>1</td><td>0</td><td>r</td><td>1</td><td>0</td> <td colspan="3"></td> </tr> <tr> <td colspan="3" style="text-align: center;">L</td> <td colspan="3" style="text-align: center;">R</td> <td colspan="3"></td> </tr> <tr> <td colspan="6"></td> <td colspan="3" style="text-align: center;">Volt. of MG sensor</td> </tr> </table>				r	0	5													Motor name							A	L	L								O	F	F										ON/OFF status			Display	Motor name	ALL	Main motor, Fin motor, and clutch	FEd	Main motor							Motor name							A	L	L				L	1	0	r	1	0				L			R												Volt. of MG sensor		
			r	0	5																																																																																																		
						Motor name																																																																																																	
				A	L	L																																																																																																	
				O	F	F																																																																																																	
						ON/OFF status																																																																																																	
Display	Motor name																																																																																																						
ALL	Main motor, Fin motor, and clutch																																																																																																						
FEd	Main motor																																																																																																						
						Motor name																																																																																																	
				A	L	L																																																																																																	
L	1	0	r	1	0																																																																																																		
L			R																																																																																																				
						Volt. of MG sensor																																																																																																	







Large (CMND)	Small (1stOP)	Data (2ndOP)	Contents	Processes
1	1	Duration	Aging mode	Turns ON/OFF main motor, fin motor for the specified duration. (Duration MAX24hrs)



Details:

- Repeat turning ON/OFF each motor at the timings like the ones at counting (ON 6 sec & OFF 6 sec) for the specified duration.
- Displays remaining time and the number of repetition.
- After correcting sensors, turns on motors and detects motor error.
- If an error is occur, log the error is logged and, displays it and finish.

Operations	Displays																																																												
<p>(1) At (Disp.1)</p> <ul style="list-style-type: none"> <li>• Pressing  key starts processing. (→ Disp.2)</li> </ul> <p>(2) At (Disp.2)</p> <ul style="list-style-type: none"> <li>• Pressing  key increased duration. (1hr a unit)</li> </ul> <p>→ 1 → 2 → 3 → 4 . . . . 24</p> <ul style="list-style-type: none"> <li>• Pressing  key increased duration. (1hr a unit)</li> </ul> <p>1 . . . . 22 ← 23 ← 24 ←</p> <ul style="list-style-type: none"> <li>• Pressing  key clears the number of repetition.</li> <li>• Pressing  key starts aging mode. (→ Disp.3)</li> </ul> <p>(3) At (Disp.3)</p> <ul style="list-style-type: none"> <li>• Pressing  key ends aging mode. (→ Disp.2)</li> <li>• Disabled to enter The other RAS command.</li> </ul>	<p>(Disp.1) Idling (After inputting commands)</p> <table border="1" style="margin-left: auto; margin-right: auto;"> <tr> <td></td><td></td><td></td><td>r</td><td>1</td><td>1</td> </tr> <tr> <td></td><td></td><td></td><td></td><td></td><td></td> </tr> </table> <p>(Disp.2) while stopped</p> <ul style="list-style-type: none"> <li>• Display duration 1hr a unit.</li> </ul> <table border="1" style="margin-left: auto; margin-right: auto;"> <tr> <td colspan="6" style="text-align: center;"><b>Duration (hrs)</b></td> </tr> <tr> <td></td><td></td><td></td><td></td><td>1</td><td>2</td> </tr> <tr> <td></td><td></td><td></td><td></td><td></td><td>0</td> </tr> <tr> <td colspan="6" style="text-align: center;">Number of repetition</td> </tr> </table> <p>(Disp.3)</p> <table border="1" style="margin-left: auto; margin-right: auto;"> <tr> <td colspan="6" style="text-align: center;"><b>Remaining time</b></td> </tr> <tr> <td></td><td></td><td></td><td></td><td>0</td><td>9</td> </tr> <tr> <td></td><td></td><td>1</td><td>8</td><td>0</td><td>0</td> </tr> <tr> <td colspan="6" style="text-align: center;">Number of repetition</td> </tr> </table>				r	1	1							<b>Duration (hrs)</b>										1	2						0	Number of repetition						<b>Remaining time</b>										0	9			1	8	0	0	Number of repetition					
			r	1	1																																																								
<b>Duration (hrs)</b>																																																													
				1	2																																																								
					0																																																								
Number of repetition																																																													
<b>Remaining time</b>																																																													
				0	9																																																								
		1	8	0	0																																																								
Number of repetition																																																													

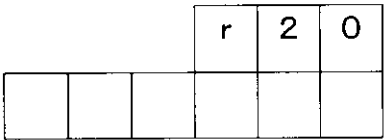
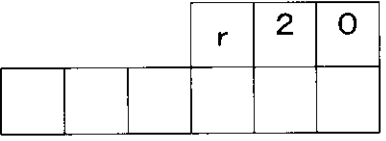
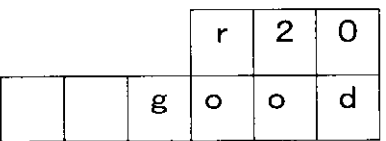
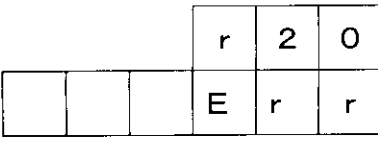
Large (CMND)	Small (1stOP)	Data (2ndOP)	Contents	Processes																		
1	2		Endurance mode	Turns ON/OFF main motor fin motor for the specified duration.																		
<b>Details:</b> <ul style="list-style-type: none"> <li>Repeat turning ON/OFF each motor at the timings of ON 4sec &amp; OFF 1sec for a regulated time.</li> <li>Display the number of repetition.</li> <li>After correcting sensors, turn on motors and check a motor error.</li> <li>If an error is occurred, log the error, display it and finish.</li> </ul>																						
Operations			Displays																			
<p>(1) At (Disp.1)</p> <ul style="list-style-type: none"> <li>Pressing  key starts processing. (→ Disp.2)</li> </ul>			<p>(Disp.1) Idling (After inputting commands)</p> <table border="1" style="margin-left: auto; margin-right: auto;"> <tr> <td></td><td></td><td></td><td>r</td><td>1</td><td>2</td> </tr> <tr> <td></td><td></td><td></td><td></td><td></td><td></td> </tr> </table>					r	1	2												
			r	1	2																	
<p>(2) At (Disp.2)</p> <ul style="list-style-type: none"> <li>Pressing  key starts endurance mode. (→ Disp.3)</li> <li>Pressing  key clears the number of repetition.</li> </ul>			<p>(Disp.2) While stopped</p> <ul style="list-style-type: none"> <li>Display regulated time 255hrs fixed.</li> </ul> <table border="1" style="margin-left: auto; margin-right: auto;"> <tr> <td colspan="6" style="text-align: center;">Duration</td> </tr> <tr> <td></td><td></td><td></td><td>2</td><td>5</td><td>5</td> </tr> <tr> <td></td><td></td><td></td><td></td><td></td><td>0</td> </tr> </table> <p style="text-align: center;">Number of repetition</p>		Duration									2	5	5						0
Duration																						
			2	5	5																	
					0																	
<p>(3) At (Disp.3)</p> <ul style="list-style-type: none"> <li>Pressing  key ends endurance mode. (→ Disp.2)</li> <li>Disabled to enter The other RAS command.</li> </ul>			<p>(Disp.3)</p> <ul style="list-style-type: none"> <li>Display remaining time 255hrs fixed.</li> </ul> <table border="1" style="margin-left: auto; margin-right: auto;"> <tr> <td colspan="6" style="text-align: center;">Duration</td> </tr> <tr> <td></td><td></td><td></td><td>2</td><td>5</td><td>5</td> </tr> <tr> <td></td><td></td><td>1</td><td>8</td><td>0</td><td>0</td> </tr> </table> <p style="text-align: center;">Number of repetition</p>		Duration									2	5	5			1	8	0	0
Duration																						
			2	5	5																	
		1	8	0	0																	

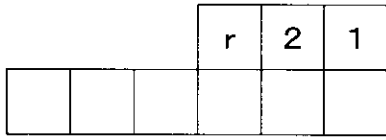
Large (CMND)	Small (1stOP)	Data (2ndOP)	Contents	Processes
2	0		Comm. loop check	Check serial communication loop.
Details: <ul style="list-style-type: none"> <li>• Checks communication loop for external communication SIO.</li> <li>• Connect a loop check connector for external communication SIO.</li> </ul>				
Operations			Displays	
(1) At (Disp.1) <ul style="list-style-type: none"> <li>• Pressing  key starts processing. (→ Disp.2)</li> </ul>			(Disp.1) Idling (After inputting commands) 	
(2) At (Disp.2) <ul style="list-style-type: none"> <li>• Normal completion (→ Disp.3)</li> <li>• Abnormal completion (→ Disp.4)</li> </ul>			(Disp.2) While processing Blinking 	
			(Disp.3) Normal completion 	
			(Disp.4) Abnormal completion 	

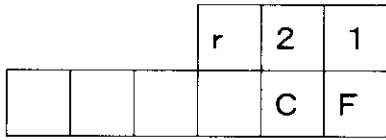

Large (CMND)	Small (1stOP)	Data (2ndOP)	Contents	Processes																										
2	1		Check a key	Displays the code corresponding to the pressed key.																										
Details: • Pressing a key displays the code corresponding to the key.																														
Operations			Displays																											
(1) At (Disp.1) • Pressing  key starts processing. (→ Disp.2)			(Disp.1) Idling (After inputting commands) 																											
(2) (Disp.2) Contents of a set No. • Pressing  or  twice continuously changes to the other RAS mode.			(Disp.2) While displaying the key code.  Key code In the case of pressing #.																											
			<table border="1"> <thead> <tr> <th>Code</th> <th>Key</th> </tr> </thead> <tbody> <tr><td>Ad</td><td>ADD</td></tr> <tr><td>CF</td><td>CF</td></tr> <tr><td>SHP</td><td>#</td></tr> <tr><td>Prt</td><td>PRINT</td></tr> <tr><td>AP</td><td>AMT/PCS</td></tr> <tr><td>SEt</td><td>SET</td></tr> <tr><td>CAL</td><td>CALL</td></tr> <tr><td>PLS</td><td>PLUS</td></tr> <tr><td>bAt</td><td>BATCH</td></tr> <tr><td>nod</td><td>MODE</td></tr> <tr><td>C</td><td>C</td></tr> <tr><td>SS</td><td>START/STOP</td></tr> </tbody> </table>		Code	Key	Ad	ADD	CF	CF	SHP	#	Prt	PRINT	AP	AMT/PCS	SEt	SET	CAL	CALL	PLS	PLUS	bAt	BATCH	nod	MODE	C	C	SS	START/STOP
Code	Key																													
Ad	ADD																													
CF	CF																													
SHP	#																													
Prt	PRINT																													
AP	AMT/PCS																													
SEt	SET																													
CAL	CALL																													
PLS	PLUS																													
bAt	BATCH																													
nod	MODE																													
C	C																													
SS	START/STOP																													



Large (CMND)	Small (1stOP)	Data (2ndOP)	Contents	Processes																								
2	2		Check LEDs	Turns ON/OFF LEDs.																								
<p>Details:</p> <ul style="list-style-type: none"> <li>Repeats turning ON/OFF of all LEDs every 2 seconds.</li> </ul>																												
Operations			Displays																									
<p>(1) At (Disp.1)</p> <ul style="list-style-type: none"> <li>Pressing  key starts processing. (→ Disp.2)</li> </ul>			<p>(Disp.1) Idling (After inputting commands)</p> <table border="1" data-bbox="926 735 1307 871"> <tr> <td></td><td></td><td></td><td>r</td><td>2</td><td>2</td> </tr> <tr> <td></td><td></td><td></td><td></td><td></td><td></td> </tr> </table>					r	2	2																		
			r	2	2																							
<p>(2) (Disp.2) Contents of a set No.</p> <ul style="list-style-type: none"> <li>Repeat Disp.2-① for 2 sec. &amp; Disp.2-② for 2 sec.</li> </ul>			<p>(Disp.2-①) While LEDs are turned on.</p> <ul style="list-style-type: none"> <li>All elements are turned on when displaying the status of ADD,CF, BATCH,DENOM,REJECT,MIX, D. D,CNT.</li> </ul> <table border="1" data-bbox="931 1127 1310 1263"> <tr> <td></td><td></td><td></td><td>8</td><td>8</td><td>8</td> </tr> <tr> <td></td><td></td><td></td><td>.</td><td>.</td><td>.</td> </tr> <tr> <td>8</td><td>8</td><td>8</td><td>8</td><td>8</td><td>8</td> </tr> <tr> <td>.</td><td>.</td><td>.</td><td>.</td><td>.</td><td>.</td> </tr> </table>					8	8	8				.	.	.	8	8	8	8	8	8	.	.	.	.	.	.
			8	8	8																							
			.	.	.																							
8	8	8	8	8	8																							
.	.	.	.	.	.																							
			<p>(Disp.2-②) While LEDs are.</p> <ul style="list-style-type: none"> <li>All elements are turned off when displaying the status of LEVEL,ADD, CF,BATCH,DENOM,MIX,D. D,CNT.</li> </ul> <table border="1" data-bbox="931 1539 1310 1675"> <tr> <td></td><td></td><td></td><td></td><td></td><td></td> </tr> <tr> <td></td><td></td><td></td><td></td><td></td><td></td> </tr> </table>																									

Large (CMND)	Small (1stOP)	Data (2ndOP)	Contents	Processes
2	3		Display ROM version, machine model.	Displays a ROM version, machine model.

Details:

- Displays ROM version, evaluation No., checksum value and machine model.

Operations	Displays																																																
<p>(1) At (Disp.1)</p> <ul style="list-style-type: none"> <li>• Pressing  key starts processing.</li> </ul> <p>(→ Disp.2)</p> <p>(2) At (Disp.2)</p> <ul style="list-style-type: none"> <li>• Pressing  key switches the display of an item.</li> </ul> <p>Item displayed</p> <p>①ROM version/Evaluation No. ↑ ↓ ③Machine model ← ②Checksum value</p> <ul style="list-style-type: none"> <li>• Pressing  key switches the display of an item.</li> </ul> <p>Item displayed</p> <p>①ROM version/Evaluation No. ↓ ↑ ④Machine model → ③Checksum value</p>	<p>(Disp.1) Idling (After inputting commands)</p> <table border="1" style="margin-left: auto; margin-right: auto;"> <tr> <td></td><td></td><td></td><td>r</td><td>2</td><td>3</td> </tr> <tr> <td></td><td></td><td></td><td></td><td></td><td></td> </tr> </table> <p>(Disp.2-①) While displaying ROM version.</p> <ul style="list-style-type: none"> <li>• ROM version/Evaluation No (0 ~ 99) are displayed in decimal numbers.</li> </ul> <table border="1" style="margin-left: auto; margin-right: auto;"> <tr> <td></td><td></td><td></td><td>r</td><td>2</td><td>3</td> </tr> <tr> <td>v</td><td>0</td><td>1</td><td>-</td><td>0</td><td>1</td> </tr> </table> <p style="text-align: center;">ROMversion Evaluation No</p> <p>(Disp.2-②) Display a checksum value.</p> <ul style="list-style-type: none"> <li>• A checksum value (0 ~ FFFFH) is displayed in hexadecimal system.</li> </ul> <table border="1" style="margin-left: auto; margin-right: auto;"> <tr> <td></td><td></td><td></td><td>r</td><td>2</td><td>3</td> </tr> <tr> <td>S</td><td>U</td><td>F</td><td>F</td><td>F</td><td>F</td> </tr> </table> <p style="text-align: center;">Checksum value</p> <p>(Disp.2-③) Display machine model.</p> <ul style="list-style-type: none"> <li>• Display a machine model (Series)</li> </ul> <table border="1" style="margin-left: auto; margin-right: auto;"> <tr> <td></td><td></td><td></td><td>g</td><td>F</td><td>r</td> </tr> <tr> <td></td><td></td><td>S</td><td>-</td><td>8</td><td>0</td> </tr> </table> <p style="text-align: center;">Machine model</p>				r	2	3										r	2	3	v	0	1	-	0	1				r	2	3	S	U	F	F	F	F				g	F	r			S	-	8	0
			r	2	3																																												
			r	2	3																																												
v	0	1	-	0	1																																												
			r	2	3																																												
S	U	F	F	F	F																																												
			g	F	r																																												
		S	-	8	0																																												



Large (CMND)	Small (1stOP)	Data (2ndOP)	Contents	Processes												
2	4		Buzzer ON/OFF	Turning ON/OFF a buzzer.												
Details: • Pressing a key turns ON/OFF a buzzer.																
Operations			Displays													
(1) At (Disp.1) • Pressing  key starts processing. (→ Disp.2)			(Disp.1) Idling (After inputting commands) <table border="1" data-bbox="912 735 1295 871"> <tr> <td></td><td></td><td></td><td>r</td><td>2</td><td>4</td> </tr> <tr> <td></td><td></td><td></td><td></td><td></td><td></td> </tr> </table>					r	2	4						
			r	2	4											
(2) At (Disp.2) • Pressing  key turn on a buzzer. (→ Disp.3)			(Disp.2) While the buzzer is turned off. <table border="1" data-bbox="912 1065 1295 1200"> <tr> <td></td><td></td><td></td><td>r</td><td>2</td><td>4</td> </tr> <tr> <td></td><td></td><td></td><td>O</td><td>F</td><td>F</td> </tr> </table>					r	2	4				O	F	F
			r	2	4											
			O	F	F											
(3) At (Disp.3) • Pressing  key turn off a buzzer. (→ Disp.3) • Disabled to enter The other RAS command.			(Disp.3) While the buzzer is turned on. <table border="1" data-bbox="923 1338 1306 1474"> <tr> <td></td><td></td><td></td><td>r</td><td>2</td><td>4</td> </tr> <tr> <td></td><td></td><td></td><td></td><td>o</td><td>n</td> </tr> </table>					r	2	4					o	n
			r	2	4											
				o	n											

Large (CMND)	Small (1stOP)	Data (2ndOP)	Contents	Processes
3	0		Display of total passed pieces.	Displays the number of total passed.

Details:

- Displays the total number of passed notes stored in the backup area.





Operations	Displays																												
<p>(1) At (Disp.1)</p> <ul style="list-style-type: none"> <li>• Pressing  key starts processing. (→ Disp.2)</li> </ul>	<p>(Disp.1) Idling (After inputting commands)</p> <table border="1" style="margin-left: auto; margin-right: auto;"> <tr> <td></td><td></td><td></td><td></td><td>r</td><td>3</td><td>0</td> </tr> <tr> <td></td><td></td><td></td><td></td><td></td><td></td><td></td> </tr> </table> <p>(Disp.2) When the process is completed. (Displays total passed pieces.)</p> <ul style="list-style-type: none"> <li>• "1" denotes 10,000 pcs.</li> <li>• Displays from 10000 pcs to 9999990000 pcs.</li> </ul> <table border="1" style="margin-left: auto; margin-right: auto;"> <tr> <td></td><td></td><td></td><td></td><td>r</td><td>3</td><td>0</td> </tr> <tr> <td>1</td><td>0</td><td>0</td><td>0</td><td>0</td><td>0</td><td>0</td> </tr> </table> <p><b>Number of total passed pieces</b> The above Display means 1000000000 pcs.</p>					r	3	0												r	3	0	1	0	0	0	0	0	0
				r	3	0																							
				r	3	0																							
1	0	0	0	0	0	0																							

Large (CMND)	Small (1stOP)	Data (2ndOP)	Contents	Processes																								
3	1	Select error code	Display of number of error occurred and rejected pieces	Displays the error code, a number of error occurred & rejected pieces for each error.																								
<p>Details:</p> <ul style="list-style-type: none"> <li>· Displays the error code, the number of the error occurred and rejected pieces caused by the error which are stored in the backup area.</li> </ul>																												
Operations			Displays																									
<p>(1) At (Disp.1)</p> <ul style="list-style-type: none"> <li>· Pressing  key starts processing. (→ Disp.2)</li> </ul> <p>(2) At (Disp.2)</p> <ul style="list-style-type: none"> <li>· Pressing  key switches the display of the error code in order shown below.</li> </ul> <p>→ EJ1 → EJ2 → EJ3 → . . . → nr5</p> <ul style="list-style-type: none"> <li>· Pressing  key switches the display of the error code in order shown below.</li> </ul> <p>EJ1 ← . . . ← CL7 ← HP ← nr5 ←</p> <p>Reject Code            EC : interval            EH : half            Ed : double            dd : different denomination            ES : skew            EF : nothing            CF : counterfeit            nr1 ~ nr5 : indiscriminated</p>			<p>(Disp.1) Idling (After inputting commands)</p> <table border="1" data-bbox="921 793 1303 929"> <tr> <td></td><td></td><td></td><td>r</td><td>3</td><td>1</td> </tr> <tr> <td></td><td></td><td></td><td></td><td></td><td></td> </tr> </table> <p>(Disp.2) While displaying.</p> <ul style="list-style-type: none"> <li>· The number of occurrence is displayed bet.0~FFFFH in hexadecimal system.</li> </ul> <p>Error code</p> <table border="1" data-bbox="926 1323 1307 1459"> <tr> <td></td><td></td><td></td><td>E</td><td>r</td><td>1</td> </tr> <tr> <td></td><td></td><td></td><td></td><td></td><td>1</td> </tr> </table> <p>Number of occurrence Er1 error occurred once.</p>					r	3	1										E	r	1						1
			r	3	1																							
			E	r	1																							
					1																							

Large (CMND)	Small (1stOP)	Data (2ndOP)	Contents	Processes
3	2	Input denom.	Displayed of passed pieces by each denom.	Displays the number of pass for each denomination.

Details:

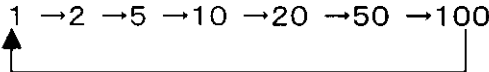

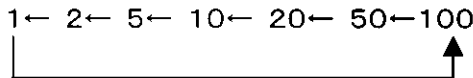
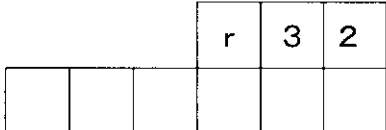
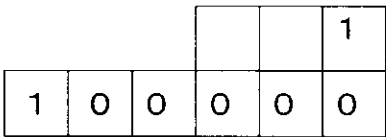

- Displaying the number of pass for each denomination which is stored in the backup area.

Operations	Displays
<p>(1) At (Disp.1)</p> <ul style="list-style-type: none"> <li>· Pressing  key starts processing. (→ Disp.2)</li> </ul> <p>(2) At (Disp.2)</p> <ul style="list-style-type: none"> <li>· Pressing  key switches the denomination.</li> </ul> <p>1 → 2 → 5 → 10 → 20 → 50 → 100</p>  <ul style="list-style-type: none"> <li>· Pressing  key switches the denomination.</li> </ul> <p>1 ← 2 ← 5 ← 10 ← 20 ← 50 ← 100</p> 	<p>(Disp.1) Idling (After inputting commands)</p>  <p>(Disp.2) While displaying</p> <ul style="list-style-type: none"> <li>· "1" denotes 100 pcs.</li> <li>· Displays from 100 pcs. to 99999900 pcs.</li> </ul> <p style="text-align: center;">Denomination</p>  <p>Number of pieces passed by denom. Display 10000000 pieces passed.</p>

Large (CMND)	Small (1stOP)	Data (2ndOP)	Contents	Processes
3	3	Select denom.	Display of manually input pieces by each denomination	Displays the number of manually input pieces for each denomination.

**Details:**

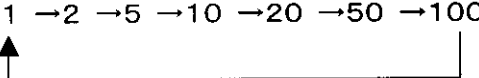
- Displays the number of manually input pieces for each denomination which is stored in the backup area.

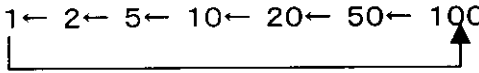

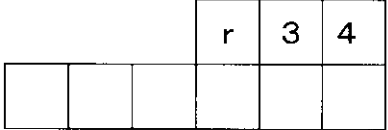
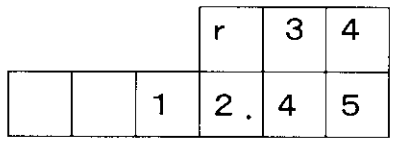

Operations	Displays																								
<p>(1) At (Disp.1)</p> <ul style="list-style-type: none"> <li>• Pressing  key starts processing. (→ Disp.2)</li> </ul> <p>(2) At (Disp.2)</p> <ul style="list-style-type: none"> <li>• Pressing  key switches the denomination in order shown below.</li> </ul> <p style="text-align: center;">1 → 2 → 5 → 10 → 20 → 50 → 100</p>  <ul style="list-style-type: none"> <li>• Pressing  key switches the denomination in order shown below.</li> </ul> <p style="text-align: center;">1 ← 2 ← 5 ← 10 ← 20 ← 50 ← 100</p> 	<p>(Disp.1) Idling (After inputting commands)</p> <table border="1" style="margin-left: auto; margin-right: auto;"> <tr> <td></td><td></td><td></td><td>r</td><td>3</td><td>3</td> </tr> <tr> <td></td><td></td><td></td><td></td><td></td><td></td> </tr> </table> <p>(Disp.2) Displaying.</p> <ul style="list-style-type: none"> <li>• "1" denotes 1 pcs.</li> <li>• Displays from 1 pcs. to 999999 pcs.</li> </ul> <p style="text-align: center;"><b>Denomination</b></p> <table border="1" style="margin-left: auto; margin-right: auto;"> <tr> <td></td><td></td><td></td><td></td><td></td><td>1</td> </tr> <tr> <td>1</td><td>0</td><td>0</td><td>0</td><td>0</td><td>0</td> </tr> </table> <p><b>Manually input pieces by denom.</b> Display manually input 100000 pcs.</p>				r	3	3												1	1	0	0	0	0	0
			r	3	3																				
					1																				
1	0	0	0	0	0																				



Large (CMND)	Small (1stOP)	Data (2ndOP)	Contents	Processes
3	4		Display of the duration of motor ON	Displays the duration when the main motor turns on.
Details: • Displays the duration when a main motor turns on and which is stored in a backup area.				
Operations			Displays	
(1) At (Disp.1) • Pressing  key starts processing. (→ Disp.2)			(Disp.1) Idling (After inputting commands) 	
			(Disp.2) When the process is completed (Displays duration of motorON) • Upper 4 digits: hour, Lower 2 digits: minutes. 	
			Total passed pieces Duration of Motor ON :12hrs 45mins is shown.	

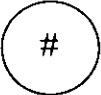

Large (CMND)	Small (1stOP)	Data (2ndOP)	Contents	Processes
4	0	Counting speed/Len. of sheet	Change speed of fin motor	Adjusts the speed of the fin motor.

**Details:**

- Set the PWM output value of the fin motor to adjust the speed.
- Set the speed of the fin motor in 16 levels. (Two types of sheets(Over 91mm, under 91mm) at the speed of 1000 pcs.per minute are counted.)
- Write set values to the backup RAM.

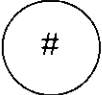
Operations	Displays																														
<p>(1) At (Disp.1)</p> <ul style="list-style-type: none"> <li>• Pressing  key starts processing. (→ Disp.2)</li> </ul>	<p>(Disp.1) Idling (After inputting commands)</p> <table border="1" style="margin-left: auto; margin-right: auto;"> <tr> <td></td><td></td><td></td><td>r</td><td>4</td><td>0</td> </tr> <tr> <td></td><td></td><td></td><td></td><td></td><td></td> </tr> </table>				r	4	0																								
			r	4	0																										
<p>(2) At (Disp.2)</p> <ul style="list-style-type: none"> <li>• Pressing  key switches a count speed/a length of a sheet in order shown below.</li> </ul> <p>Count speed/Length of a sheet</p> <table border="1" style="margin-left: auto; margin-right: auto;"> <tr> <td style="text-align: center;">▶</td> <td style="text-align: center;">10L → 10S</td> <td style="text-align: center;">◻</td> </tr> </table> <ul style="list-style-type: none"> <li>• Pressing  key switches count speed/ a length of a sheet in order shown below.</li> </ul> <p>Count speed/Length of a sheet</p> <table border="1" style="margin-left: auto; margin-right: auto;"> <tr> <td style="text-align: center;">◻</td> <td style="text-align: center;">10L → 10S</td> <td style="text-align: center;">◀</td> </tr> </table> <ul style="list-style-type: none"> <li>• Pressing  key makes the input mode of the fin motor speed. (→ Disp.3)</li> <li>• Pressing  key accepts the data. (→ Disp.4)</li> </ul>	▶	10L → 10S	◻	◻	10L → 10S	◀	<p>(Disp.2) Selecting count speed / Length</p> <table border="1" style="margin-left: auto; margin-right: auto;"> <tr> <td colspan="3"></td> <td colspan="3" style="text-align: center;">Input value</td> </tr> <tr> <td></td><td></td><td></td><td></td><td></td><td>7</td> </tr> <tr> <td>1</td><td>0</td><td>L.</td><td></td><td></td><td>7</td> </tr> </table> <p style="text-align: center;">Count speed/Len. Present value</p> <p>When in the normal RAS mode, the dot in the 2nd lowest digit of the counter is lit up</p> <table border="1" style="margin-left: auto; margin-right: auto;"> <thead> <tr> <th>Display</th> <th>Count speed/Length</th> </tr> </thead> <tbody> <tr> <td>10L</td> <td>1000pcs·min/Over91mm</td> </tr> <tr> <td>10S</td> <td>1000pcs·min/Under90mm</td> </tr> </tbody> </table>				Input value								7	1	0	L.			7	Display	Count speed/Length	10L	1000pcs·min/Over91mm	10S	1000pcs·min/Under90mm
▶	10L → 10S	◻																													
◻	10L → 10S	◀																													
			Input value																												
					7																										
1	0	L.			7																										
Display	Count speed/Length																														
10L	1000pcs·min/Over91mm																														
10S	1000pcs·min/Under90mm																														

Operations	Displays																																				
<p>(3) At (Disp.3)</p> <ul style="list-style-type: none"> <li>Pressing  key increases the speed value of the fin motor.</li> </ul> <p>→ 0 → 1 → 2 → 3 . . . 15</p> <ul style="list-style-type: none"> <li>Pressing  key reduces the speed value of the fin motor.</li> </ul> <p>0 ← 1 . . . 13 ← 14 ← 15 ←</p> <ul style="list-style-type: none"> <li>Pressing  key selects the mode from count speed/length. (→ Disp.2)</li> <li>Pressing  key accepts the data. (→ Disp.4)</li> </ul>	<p>(Disp.3) Inputting a speed of a fin motor.</p> <table border="1" data-bbox="915 439 1298 607"> <tr> <td colspan="3"></td> <td colspan="3">Input value</td> </tr> <tr> <td colspan="3"></td> <td></td> <td></td> <td>8</td> </tr> <tr> <td>1</td> <td>0</td> <td>L</td> <td></td> <td></td> <td>7</td> </tr> </table> <p>Count Speed/Length Present value</p> <p>When in the normal RAS mode, the dot in the 2nd lowest digit of the counter is lit up.</p> <p>(Disp.4) Acceptance of data</p> <ul style="list-style-type: none"> <li>The input value becomes the present value.</li> </ul> <table border="1" data-bbox="915 1259 1298 1427"> <tr> <td colspan="3"></td> <td colspan="3">Input value</td> </tr> <tr> <td colspan="3"></td> <td></td> <td></td> <td>8</td> </tr> <tr> <td>1</td> <td>0</td> <td>L</td> <td></td> <td></td> <td>8</td> </tr> </table> <p>Count speed/Length Present value</p>				Input value								8	1	0	L			7				Input value								8	1	0	L			8
			Input value																																		
					8																																
1	0	L			7																																
			Input value																																		
					8																																
1	0	L			8																																

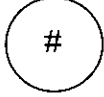
Large (CMND)	Small (1stOP)	Data (2ndOP)	Contents	Processes																																																
4	2		Set the buzzer ON/OFF	Turns the buzzer ON/OFF.																																																
<b>Details:</b> <ul style="list-style-type: none"> <li>• Sets the buzzer ON/OFF.</li> <li>• Values set are written in the backup RAM.</li> </ul>																																																				
Operations			Displays																																																	
<p>(1) At (Disp.1)</p> <ul style="list-style-type: none"> <li>• Pressing  key starts processing. (→ Disp.2)</li> </ul> <p>(2) At (Disp.2-①)</p> <ul style="list-style-type: none"> <li>• Pressing  or  key selects ON/OFF.</li> </ul> <p>(Disp.2-① ↔ Disp.2-②)</p> <ul style="list-style-type: none"> <li>• Pressing  key accepts the data. (→ Disp.3)</li> </ul>			<p>(Disp.1) Idling (After inputting commands)</p> <table border="1" style="margin-left: auto; margin-right: auto;"> <tr> <td></td><td></td><td></td><td>r</td><td>4</td><td>2</td> </tr> <tr> <td></td><td></td><td></td><td></td><td></td><td></td> </tr> </table> <p>(Disp.2-①) Selecting ON/OFF</p> <table border="1" style="margin-left: auto; margin-right: auto;"> <tr> <td></td><td></td><td></td><td>r</td><td>4</td><td>2</td> </tr> <tr> <td></td><td></td><td></td><td></td><td>o</td><td>n.</td> </tr> </table> <p>When in the normal RAS mode, the dot in the 2nd lowest digit of the counter is lit up.</p> <p>(Disp.2-②)</p> <table border="1" style="margin-left: auto; margin-right: auto;"> <tr> <td></td><td></td><td></td><td>r</td><td>4</td><td>2</td> </tr> <tr> <td></td><td></td><td></td><td>O</td><td>F</td><td>F.</td> </tr> </table> <p>(Disp.3)</p> <table border="1" style="margin-left: auto; margin-right: auto;"> <tr> <td></td><td></td><td></td><td>r</td><td>4</td><td>2</td> </tr> <tr> <td></td><td></td><td></td><td></td><td>o</td><td>n</td> </tr> </table>					r	4	2										r	4	2					o	n.				r	4	2				O	F	F.				r	4	2					o	n
			r	4	2																																															
			r	4	2																																															
				o	n.																																															
			r	4	2																																															
			O	F	F.																																															
			r	4	2																																															
				o	n																																															



Large (CMND)	Small (1stOP)	Data (2ndOP)	Contents	Processes												
5	0		Normal mode	Enters into a normal mode. (Transmits recognition data.)												
Details: • Transmits recognition data. • This function is effective until turning off the power.																
Operations			Displays													
(1) At (Disp1) • Pressing  key starts processing. (→ disp.2)			(Disp.1) Idling (After entering commands) <table border="1" data-bbox="932 743 1317 883"> <tr> <td></td><td></td><td></td><td>r</td><td>5</td><td>0</td> </tr> <tr> <td></td><td></td><td></td><td></td><td></td><td></td> </tr> </table>					r	5	0						
			r	5	0											
(2) At (Disp.2) • Normal RAS mode ends by turning off power.			(Disp.2) Normal RAS mode. <table border="1" data-bbox="932 1013 1317 1153"> <tr> <td></td><td></td><td></td><td></td><td></td><td></td> </tr> <tr> <td></td><td></td><td></td><td></td><td>.</td><td>0</td> </tr> </table> <p>When in the normal RAS mode, the dot in the 2nd lowest digit of the counter is lit up.</p>												.	0
				.	0											



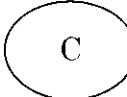

Large (CMND)	Small (1stOP)	Data (2ndOP)	Contents	Processes												
5	1		Normal mode	Enters into the normal mode. (Detecting even when a genuine currency is processed CF)												
<b>Details:</b> <ul style="list-style-type: none"> <li>• Enter into the normal mode from RAS mode.</li> <li>• Transmits CF data.</li> <li>• Rejects a genuine currency by CF(Buzzer, LED).</li> <li>• Effective until turning off a power.</li> </ul>																
Operations			Displays													
<p>(1) At (Disp.1)</p> <ul style="list-style-type: none"> <li>• Pressing  key starts processing. (→ disp.2)</li> </ul>			<p>(Disp.1) Idling (After entering commands)</p> <table border="1" style="margin-left: auto; margin-right: auto;"> <tr> <td></td><td></td><td></td><td>r</td><td>5</td><td>1</td> </tr> <tr> <td></td><td></td><td></td><td></td><td></td><td></td> </tr> </table>					r	5	1						
			r	5	1											
<p>(2) At (Disp.2)</p> <ul style="list-style-type: none"> <li>• Normal RAS mode ends by turning off a power.</li> </ul>			<p>(Disp.2) Normal RAS mode.</p> <table border="1" style="margin-left: auto; margin-right: auto;"> <tr> <td></td><td></td><td></td><td></td><td></td><td></td> </tr> <tr> <td></td><td></td><td></td><td>.</td><td></td><td>0</td> </tr> </table> <p>When in the normal RAS mode, the dot in the 2nd lowest digit of the counter is lit up.</p>											.		0
			.		0											

Large (CMND)	Small (1stOP)	Data (2ndOP)	Contents	Processes
9	0		Clear number of errors	Clears the number of each error stored as log data.





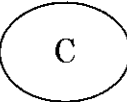

Details:

- Clears the number of each error stored in log.
- Increases the number of a log data clear parameter by one.

Operations	Displays																								
<p>(1) At (Disp.1)</p> <ul style="list-style-type: none"> <li>· Pressing  key starts processing. (→ Disp.2)</li> </ul>	<p>(Disp.1) Idling (After entering commands)</p> <table border="1" style="margin-left: auto; margin-right: auto;"> <tr> <td></td><td></td><td></td><td>r</td><td>9</td><td>0</td> </tr> <tr> <td></td><td></td><td></td><td></td><td></td><td></td> </tr> </table>				r	9	0																		
			r	9	0																				
<p>(2) At (Disp.2)</p> <ul style="list-style-type: none"> <li>· Pressing  key clears the data. (→ Disp.3)</li> <li>· Pressing  key ends without clearing the data. (→ Disp.1)</li> </ul>	<p>(Disp.2) Confirmation.</p> <table border="1" style="margin-left: auto; margin-right: auto;"> <tr> <td></td><td></td><td></td><td>r</td><td>9</td><td>0</td> </tr> <tr> <td></td><td></td><td></td><td>y</td><td>-</td><td>n</td> </tr> </table> <p>(Disp.3) Completion of process</p> <table border="1" style="margin-left: auto; margin-right: auto;"> <tr> <td></td><td></td><td></td><td>r</td><td>9</td><td>0</td> </tr> <tr> <td></td><td></td><td></td><td>E</td><td>n</td><td>d</td> </tr> </table>				r	9	0				y	-	n				r	9	0				E	n	d
			r	9	0																				
			y	-	n																				
			r	9	0																				
			E	n	d																				

Large (CMND)	Small (1stOP)	Data (2ndOP)	Contents	Processes												
9	1		Clear the number of each error, total passed pieces, motor ON time	Clears the number of each error, total passed pieces, and rejected pieces, motor ON time in log.												
<b>Details:</b> <ul style="list-style-type: none"> <li>· Clears the number of each error, total passed pieces, rejected pieces, motor ON time in log.</li> <li>· Increase the number of a log data clear parameter by one.</li> </ul>																
<b>Operations</b>			<b>Displays</b>													
<p>(1) At (Disp.1)</p> <ul style="list-style-type: none"> <li>· Pressing  key starts processing. (→ Disp.2)</li> </ul>			<p>(Disp.1) Idling (After entering commands)</p> <table border="1" style="margin-left: auto; margin-right: auto;"> <tr> <td></td><td></td><td></td><td>r</td><td>9</td><td>1</td> </tr> <tr> <td></td><td></td><td></td><td></td><td></td><td></td> </tr> </table> <p>ADD Display ●</p> <p>● : OFF    ○ : ON</p>					r	9	1						
			r	9	1											
<p>(2) At (Disp.2)</p> <ul style="list-style-type: none"> <li>· Pressing  key makes the process proceed to clearing data. (→ Disp.3)</li> <li>· Pressing  key makes the process proceed to clearing data. (→ Disp.1)</li> </ul>			<p>(Disp.2) Confirmation</p> <table border="1" style="margin-left: auto; margin-right: auto;"> <tr> <td></td><td></td><td></td><td>r</td><td>9</td><td>1</td> </tr> <tr> <td></td><td></td><td></td><td>y</td><td>-</td><td>n</td> </tr> </table>					r	9	1				y	-	n
			r	9	1											
			y	-	n											
<p>(3) At (Disp.3)</p> <ul style="list-style-type: none"> <li>· Pressing  key clears the data. (→ Disp.4)</li> <li>· Pressing  key makes the process end clearing the data. (→ Disp.1)</li> </ul>			<p>(Disp.3) Confirmation</p> <p>ADD Display ○</p> <p>● : OFF    ○ : ON</p> <p>(Disp.4) Completion of process.</p> <table border="1" style="margin-left: auto; margin-right: auto;"> <tr> <td></td><td></td><td></td><td>r</td><td>9</td><td>1</td> </tr> <tr> <td></td><td></td><td></td><td>E</td><td>n</td><td>d</td> </tr> </table>					r	9	1				E	n	d
			r	9	1											
			E	n	d											

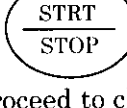

Large (CMND)	Small (1stOP)	Data (2ndOP)	Contents	Processes																																				
9	3		Process RAS91, 92 at once	Clear the number of each error, passed pieces, rejected pieces, motor ON time in a log and set default values.																																				
<b>Details:</b> <ul style="list-style-type: none"> <li>· Clears the number of each error, passed pieces, rejected pieces, motor ON time in a log.</li> <li>· Sets default values in the number of a log data clear parameter.</li> </ul>																																								
Operations			Displays																																					
<p>(1) At (Disp.1)</p> <ul style="list-style-type: none"> <li>· Pressing  key starts processing. (→ Disp.2)</li> </ul> <p>(2) At (Disp.2)</p> <ul style="list-style-type: none"> <li>· Pressing  key goes makes the process proceed to clearing data. (→ Disp.3)</li> <li>· Pressing  key goes makes the process proceed to clearing data. (→ Disp.1)</li> </ul> <p>(3) At (Disp.3)</p> <ul style="list-style-type: none"> <li>· Pressing  key goes makes the process proceed to clearing data. (→ Disp.4)</li> <li>· Pressing  key goes makes the process proceed to clearing data. (→ Disp.1)</li> </ul> <p>(4) At (Disp.4)</p> <ul style="list-style-type: none"> <li>· Pressing  key goes makes the process proceed to clearing data. (→ Disp.5)</li> <li>· Pressing  key goes makes the process proceed to clearing data. (→ Disp.1)</li> </ul>			<p>(Disp.1) Idling (After entering commands)</p> <table border="1" style="margin-left: auto; margin-right: auto;"> <tr> <td></td><td></td><td></td><td>r</td><td>9</td><td>3</td> </tr> <tr> <td></td><td></td><td></td><td></td><td></td><td></td> </tr> </table> <p>ADD Display ● CF Display ●</p> <p>● : OFF ○ : ON</p> <p>(Disp.2) Confirmation.</p> <table border="1" style="margin-left: auto; margin-right: auto;"> <tr> <td></td><td></td><td></td><td>r</td><td>9</td><td>3</td> </tr> <tr> <td></td><td></td><td></td><td>y</td><td>-</td><td>n</td> </tr> </table> <p>(Disp.3) Confirmation.</p> <p>ADD Display ○ CF Display ●</p> <p>● : OFF ○ : ON</p> <p>(Disp.4) Confirmation.</p> <p>ADD Display ○ CF Display ○</p> <p>● : OFF ○ : ON</p> <p>(Disp.5) Completion of process.</p> <table border="1" style="margin-left: auto; margin-right: auto;"> <tr> <td></td><td></td><td></td><td>r</td><td>9</td><td>3</td> </tr> <tr> <td></td><td></td><td></td><td>E</td><td>n</td><td>d</td> </tr> </table>					r	9	3										r	9	3				y	-	n				r	9	3				E	n	d
			r	9	3																																			
			r	9	3																																			
			y	-	n																																			
			r	9	3																																			
			E	n	d																																			

## 9. T r o u b l e s h o o t i n g

### 【1】Display of error code

Display an error code at the upper 3 digits (Batch/Denomination) when an error occurs.

			E	r	1

### 【2】Clearing an error

Solve the cause of an error and press  key to erase the error code displayed.

**[3]List of error codes**

Error code	Contents	How to clear
EJ1	Currency remaining at SP2	After removing pieces, press C key.
EJ2	Jam at SP2	After removing pieces, press C key.
E o	Over counted	After removing pieces, press C key.
Er1	Motor rotation malfunction	After removing pieces, press C key.
(Er2)	reserved	
Er3	SP1L sensor correction error	Press C key.
Er4	SP1R sensor correction error	Press C key.
Er5	SP2L sensor correction error	Press C key.
Er6	SP2R sensor correction error	Press C key.
Er7	Stacker sensor correction error	Press C key.
Er8	RJ sensor correction error	Press C key.
CL1	SP1L sensor cleaning	After cleaning the sensor, press C key.
CL2	SP1R sensor cleaning	After cleaning the sensor, press C key.
CL3	SP2L sensor cleaning	After cleaning the sensor, press C key.
CL4	SP2R sensor cleaning	After cleaning the sensor, press C key.
CL5	Hopper sensor cleaning	After cleaning the sensor, press C key.
CL6	Stacker sensor cleaning	After cleaning the sensor, press C key.
CL7	RJ sensor cleaning	After cleaning the sensor, press C key.
HP(FEd)	Feed error	Put currency on the hopper again, press START/STOP key.
P r	Printer error	After checking the printer, press C key.
n v	Backup area sum error	Press C key.

**【4】 Error detecting condition**

Error code	Contents	Detecting conditions (Check timing)	Causes	Confirmations	Solutions	
					Solving process	Recovering process
E J 1	J a m	<p><b>[Detecting conditions]</b> When count sensor L or R is blocked.</p> <p><b>[Check timing]</b></p> <ol style="list-style-type: none"> <li>1. Power ON</li> <li>2. Start counting (Before rotating motor)</li> <li>3. End counting (After stopping motor)</li> <li>4. When C key, or <b>START/STOP</b> key is pressed.</li> </ol>	<ul style="list-style-type: none"> <li>· Currency remains</li> <li>· Stain on sensors, flaw, adhesion of foreign material</li> <li>· Sensor malfunction</li> <li>· Sensor correction malfunction</li> <li>· Coming out or unlock of connectors</li> <li>· Harnesses breakage</li> <li>· Board malfunction</li> </ul>	<ul style="list-style-type: none"> <li>· Visually inspect around sensors</li> <li>· Display sensors' conditions and voltages with RAS</li> <li>· Check harnesses</li> <li>· Check boards</li> </ul>	<ul style="list-style-type: none"> <li>· Remove remaining currency</li> <li>· Adjust sensors with RAS</li> <li>· Exchange sensors</li> <li>· Exchange boards</li> </ul>	<p>After clearing causes, (Taking out currency from the stacker) press C key or power <b>OFF/ON</b>.</p>

Error code	Contents	Detecting conditions (Check timing)	Causes	Confirmations	Solutions	
					Solving process	Recovering process
E J 2	Jam at S P 2	<p><b>[Detecting conditions]</b> Blocked condition of SP2 continues more than 60ms after SP2 is blocked.</p> <p><b>[Check timing]</b> 1. During counting</p>	<ul style="list-style-type: none"> <li>· Abnormal currency transport</li> <li>· Sensor malfunction</li> <li>· Connector unlocked</li> <li>· Board malfunction</li> </ul>	<ul style="list-style-type: none"> <li>· Visually inspect transport root (Around S P 2)</li> <li>· Display sensors' conditions and voltages with RAS</li> <li>· Check harnesses</li> <li>· Check boards</li> </ul>	<ul style="list-style-type: none"> <li>· Remove remaining currency</li> <li>· Exchange sensors</li> <li>· Exchange boards</li> </ul>	<p>After clearing causes, (Taking out currency from the stacker) press C key</p> <p>OR</p> <p>Power OFF/ON.</p>
E o	Over counted	<p><b>[Detecting conditions]</b> When rejected currency is transported to the stacker. (When the conditions below are satisfied.)</p> <ol style="list-style-type: none"> <li>1. The previous currency went to the stacker.</li> <li>2. The next piece went to the reject stacker.</li> <li>3. Separation movement of a previous piece completed</li> <li>4. Pitch bet. these pieces is less than 85 pulses.)</li> </ol> <p><b>[Check timing]</b> 1. During counting</p>	<ul style="list-style-type: none"> <li>· Abnormal currency transport</li> <li>· Chained currency</li> </ul>	<ul style="list-style-type: none"> <li>· Check gate</li> </ul>	<ul style="list-style-type: none"> <li>· Adjust gate</li> </ul>	<p>After clearing causes, (Taking out currency from the stacker) press C key or power OFF/ON.</p>

Error code	Contents	Detecting condition (Check timing)	Causes	Confirmations	Solutions	
					Solving process	Recovering process
E r 1	Motor rotation malfunction	[Detecting conditions] 1. The maximum or minimum value of the PWM output is output for more than 2.5sec consecutively.	<ul style="list-style-type: none"> <li>Motor malfunction</li> <li>Dusts on encoder</li> <li>Interrupter malfunction</li> <li>Coming out or unlock of connectors</li> <li>Harnesses breakage</li> <li>Board malfunction</li> </ul>	<ul style="list-style-type: none"> <li>Check around the encoder</li> <li>Check harnesses</li> <li>Set motors ON/OFF with RAS</li> <li>Check boards</li> </ul>	<ul style="list-style-type: none"> <li>Cleaning around the encoder</li> <li>Exchange sensors</li> <li>Exchange boards</li> <li>Exchange motors</li> </ul>	After clearing causes, (Taking out currency from the stacker) press C key or power OFF/ON.
	Motor rotation malfunction CHIK REAL SOL. TECH	2. While counting a case of 3 pulses or less for 10ms occur over 21 times continuously. [Check timing] 1. During counting				
E r 2	Reserved	[Detecting conditions] [Check timing]				

Error code	Contents	Detecting conditions (Check timing)	Causes	Confirmations	Solutions					
					Solving process	Recovering process				
Er 3	Sensor correction error	<p><b>[Detecting conditions]</b></p> <p>1. The sensor is not blocked when D/A output for sensor correction is 0V.</p> <p>2. Out of adjustment range (3. 0 ± 0. 2 V) when D/A min. value(0) for sensor correction is output.</p> <p>3. When the process of sensor correction does not finish within 2 sec.</p> <p><b>[Check timing]</b></p> <p>1. Power ON</p> <p>2. Before counting process</p> <p>But no correction is conducted while the sensors are shaded.</p>	<ul style="list-style-type: none"> <li>• Stain on sensors</li> <li>flaw, adhesion</li> <li>• Sensor malfunction</li> <li>• Sensor correction malfunction</li> <li>• Coming out or unblock of connectors</li> <li>• Board malfunction</li> </ul>	<ul style="list-style-type: none"> <li>• Visually inspect around sensors</li> <li>• Display sensors' conditions and voltages with RAS</li> <li>• Check harnesses</li> <li>• Check boards</li> </ul>	<ul style="list-style-type: none"> <li>• Cleaning sensors</li> <li>• Adjust sensors with RAS</li> <li>• Exchange sensors</li> <li>• Exchange boards</li> </ul>	<ul style="list-style-type: none"> <li>• After clearing out currency from the stacker)</li> <li>press C key</li> <li>or</li> <li>power</li> <li>OFF/ON.</li> </ul>				
	SP1L sensor correction error						<p><b>[Detecting conditions]</b></p> <p>Same as Er 3</p> <p><b>[Check timing]</b></p> <p>Same as Er 3</p>	Same as Er 3	Same as Er 3	Same as Er 3
	SP1R sensor correction error									

Error code	Contents	Detecting conditions (Check timing)	Causes	Confirmations	Solutions	
					Solving process	Recovering process
Er 5	SP 2 L sensor	[Detecting conditions] Same as Er 3	Same as Er 3	Same as Er 3	Same as Er 3	Same as Er 3
	correction error	[Check timing] Same as Er 3				
Er 6	SP 2 R sensor	[Detecting conditions] Same as Er 3	Same as Er 3	Same as Er 3	Same as Er 3	Same as Er 3
	correction error	[Check timing] Same as Er 3				

Error code	Contents	Detecting conditions (Check timing)	Causes	Confirmations	Solutions	
					Solving process	Recovering process
E r 7	Stacker sensor	<p>[Detecting conditions]</p> <p>1. The A/D value is over 4.5V when D/V output for sensor correction is 0V.</p> <p>2. Out of adjustment range (3.0 ± 0.2 V) when D/A min. value(0) for sensor correction is output.</p> <p>3. When the process of sensor correction does not finish within 2 sec.</p> <p>[Check timing]</p> <p>1. Power ON</p> <p>2. Before counting process</p> <p>But no correction is conducted while the sensors are shaded.</p>	Same as E r 3	Same as E r 3	Same as E r 3	Same as E r 3
	correction error					
E r 8	R/J sensor	<p>[Detecting conditions]</p> <p>Same as E r 7</p> <p>[Check timing]</p> <p>Same as E r 7</p>	Same as E r 3	Same as E r 3	Same as E r 3	Same as E r 3
	correction error					

Error code	Contents	Detecting conditions (Check timing)	Causes	Confirmations	Solutions	
					Solving process	Recovering process
CL1	Sensor cleaning	<p><b>[Detecting conditions]</b>            The A/D value is out of adjustment range (3. <math>0 \pm 0.2V</math>) even if D/A max. value(255) for sensor correction is output.</p> <p><b>[Check timing]</b>            1. Power ON            2. Before counting start (Display only after counting when no other error occurs.)</p> <p>But don't correct sensors while the sensors are shaded.</p>	<ul style="list-style-type: none"> <li>• Stain on sensors</li> <li>• Sensor malfunction</li> <li>• Sensor correction malfunction</li> <li>• Coming out or unblock of connectors</li> <li>• Board malfunction</li> </ul>	<ul style="list-style-type: none"> <li>• Visually inspect around sensors</li> <li>• Display sensors' conditions and voltages with RAS</li> <li>• Check harnesses</li> <li>• Check boards</li> </ul>	<ul style="list-style-type: none"> <li>• Cleaning sensors</li> <li>• Adjust sensors with RAS</li> <li>• Exchange sensors</li> <li>• Exchange boards</li> </ul>	<ul style="list-style-type: none"> <li>• After clearing causes, (Taking out currency from the stacker)</li> <li>• press C key</li> <li>• or</li> <li>• power OFF/ON.</li> </ul>
	SP1L sensor					
	cleaning					
CL2	SP1R sensor	<p><b>[Detecting conditions]</b>            Same as CL1</p> <p><b>[Check timing]</b>            Same as CL1</p>	Same as CL1	Same as CL1	Same as CL1	Same as CL1
	cleaning					

Error code	Contents	Detecting conditions (Check timing)	Causes	Confirmations	Solutions	
					Solving process	Recovering process
CL 3	SP 2 L sensor	[Detecting conditions] Same as CL 1	Same as CL 1	Same as CL 1	Same as CL 1	Same as CL 1
	cleaning	[Check timing] Same as CL 1				
CL 4	SP 2 R sensor	[Detecting conditions] Same as CL 1	Same as CL 1	Same as CL 1	Same as CL 1	Same as CL 1
	cleaning	[Check timing] Same as CL 1				

Error code	Contents	Detecting conditions (Check timing)	Causes	Confirmations	Solutions	
					Solving process	Recovering process
CL 5	Hopper sensor cleaning	<p><b>[Detecting conditions]</b>  1. V difference at sensor correction is more than 1.7 times of V dif. At auto-adjustment <math>\times 1.7</math>.</p> <p>2. V difference at sensor correction is less than twice of V dif. at auto-adjustment.</p> <p><b>[Check timing]</b>  1. Power ON (No other errors occur.)  But don't correct sensors while the sensors are shaded.</p>	Same as CL 1	Same as CL 1	Same as CL 1	Same as CL 1
CL 6	Stacker sensor cleaning	<p><b>[Detecting conditions]</b>  The A/D value is out of adjustment range ( <math>1.5 \pm 0.2</math> V ) even if D/A max. value(255) for sensor correction is output.</p> <p><b>[Check timing]</b>  1. Power ON  2. Before counting start (Display only after counting when no other error occurs.)  But no correction is conducted while the sensors are shaded.</p>	Same as CL 1	Same as CL 1	Same as CL 1	Same as CL 1



Error code	Contents	Detecting conditions (Check timing)	Causes	Confirmations	Solutions	
					Solving process	Recovering process
H P ( F E d )	<b>Feed error</b>	<b>[Detecting conditions]]</b> 1. During counting process, S P 2 sensor is not blocked for 2seconds.	<ul style="list-style-type: none"> <li>· Wrong set of the currency on a hopper.</li> <li>· Abnormal currency transport</li> <li>· Improper gate adjustment</li> </ul>	<ul style="list-style-type: none"> <li>· Check currency on the hopper</li> <li>· Visually inspect currency transport path</li> <li>· Check the gate</li> </ul>	<ul style="list-style-type: none"> <li>· Adjust the gate</li> </ul>	<ul style="list-style-type: none"> <li>· After putting currency on the hopper again, press START/STOP key.</li> </ul>
	Feed error	<b>[Check timing]</b> 1. During counting (with clutch ON) But all motors stop and no error display. ( Display during R A S mode)				
P r	<b>Printer error</b>	<b>[Detecting conditions]</b> 1. A printer is not ready when it begins to print out.	<ul style="list-style-type: none"> <li>· Printer malfunction</li> <li>· Printer disconnection</li> </ul>	<ul style="list-style-type: none"> <li>Check a printer</li> </ul>	<ul style="list-style-type: none"> <li>· Connect a printer properly</li> <li>· Make the printer ready.</li> </ul>	<ul style="list-style-type: none"> <li>Press C key</li> </ul>
	Printer error	<b>[Check timing]</b> 1. When the printer starts to print.				



10. GENERAL WIRING DIAGRAM

